

Command Module and Drive Module

Site Preparation Guide

AP1172-E1, First Edition

Proprietary Rights Notice

This document contains proprietary information of LSI Logic Corporation. The information contained herein is not to be used by or disclosed to third parties without the express written permission of an officer of LSI Logic Corporation. Any product(s) described herein is/are a licensed product of LSI Logic Corporation.

Document Description

Document AP1172-E1, First Edition. September 2002

This document describes site preparation for the installation of LSI Logic Corporation's E4400, E4600, and E5600 command modules, the FC-1 10x, FC-1 14x, and FC-2 14x drive modules, the E2400 10x and E2400 14x array modules, and the 72-inch cabinet and will remain the official reference source for all revisions/releases of this product until rescinded by an update.

Intended Readers

This book is intended for end users, system operators, system administrators, and service technicians who are responsible for installing hardware. Readers should have knowledge of hardware installation and operation and understand Redundant Array of Independent Disks (RAID), Small Computer System Interface (SCSI), and Fibre Channel (FC).

Disclaimer

It is the policy of LSI Logic to improve products as new technology, components, software, and firmware become available. LSI Logic Corporation reserves the right to make changes to any products herein at any time without notice. All features, functions, and operations described herein may not be marketed by LSI Logic in all parts of the world. In some instances, photographs and figures are of equipment prototypes. Therefore, before using this document, consult your LSI Logic representative for information that is applicable and current. LSI LOGIC DOES NOT ASSUME ANY RESPONSIBILITY OR LIABILITY FOR THE USE OF ANY PRODUCT(S) DESCRIBED HEREIN EXCEPT AS EXPRESSLY AGREED TO IN WRITING BY LSI LOGIC.

License Restriction

The purchase or use of an LSI Logic product does not convey a license under any patent, copyright, trademark, or other intellectual property right of LSI Logic or third parties.

Copyright Notice

© 2002. LSI Logic Corporation. All rights reserved.

Trademark Acknowledgments

LSI Logic, the LSI Logic logo, and SYMplicity are trademarks or registered trademarks of LSI Logic Corporation. All other brand and product names may be trademarks of their respective companies.

Regulatory Compliance Statements

FCC Radio Frequency Interference Statement

This equipment has been tested and found to comply with the limits for a Class A digital device, pursuant to Part 15 of the Federal Communications Commission (FCC) Rules. These limits are designed to provide reasonable protection against harmful interference in a commercial installation. This equipment generates, uses, and can radiate radio frequency energy and, if not installed and used in accordance with the instructions, may cause harmful interference to radio communications. Operation of this equipment in a residential area is likely to cause harmful interference, in which case the user will be required to correct the interference at his own expense.

LSI Logic Corporation is not responsible for any radio or television interference caused by unauthorized modification of this equipment or the substitution or attachment of connecting cables and equipment other than those specified by LSI Logic Corporation. It is the user's responsibility to correct interference caused by such unauthorized modification, substitution, or attachment.

Laser Products Statement

This equipment has been tested and found to comply with regulations for Class 1 laser product pursuant to 21 CFR, Section 1040-10. For outside the USA, this equipment has been tested and found compliant with Class 1 laser product requirements contained in European Normalization standard EN 60825-1 1994+A11. Class 1 levels of laser radiation are not considered to be hazardous and are considered safe based upon current medical knowledge. This class includes all lasers or laser systems which cannot emit levels of optical radiation above the exposure limits for the eye under any exposure conditions inherent in the design of the laser product.

LSI Logic Corporation is not responsible for any damage or injury caused by unauthorized modification of this equipment or the substitution or attachment of connecting cables and equipment other than those specified by LSI Logic Corporation. It is the user's responsibility to correct interference caused by such unauthorized modification, substitution, or attachment.

This Class A digital apparatus meets all requirements of the Canadian Interference-Causing Equipment Regulations.

Cet appareil numérique de la classé A respecte toutes les exigences du Règlement sur le matériel brouilleur du Canada.

この装置は、第一種情報装置（商工業地域において使用されるべき情報装置）で商工業地域での電波障害防止を目的とした情報処理装置等電波障害自主規制協議会（VCCI）基準に適合しております。

従って、住宅地域またはその隣接した地域で使用すると、ラジオ、テレビジョン受信機等に受信障害を与えることがあります。

取扱説明書に従って正しい取り扱いをして下さい。

警告使用者： 這是甲類的資訊產品，在居住的環境中使用時，可能會造成射頻干擾，在這種情況下，使用者會被要求採取某些適當的對策。

Revision Record

Edition or Revision	Date	Affected Pages or Remarks
First Edition	September 2002	New Book.

Part Number: AP1172-E1

Contents

Chapter 1: 72-INCH CABINET SITE PREPARATION

Cabinet Features	1-2
Area Requirements	1-4
Weights	1-5
Dimensions.....	1-6
Environmental Requirements.....	1-7
Power Requirements	1-8
AC Power Distribution Boxes	1-9
Ladder Cords.....	1-10
Power Cords and Receptacles.....	1-11
Site Wiring.....	1-12

Chapter 2: COMMAND MODULE SITE PREPARATION

Area Requirements	2-2
Weights	2-2
Dimensions.....	2-4
Shipping Carton Dimensions.....	2-4
Airflow	2-5
Environmental Requirements.....	2-6
Power Requirements	2-8
Power Cord Routing.....	2-8
Site Wiring.....	2-11
Interface Cables and Connections.....	2-12
E4400 Command Module	2-12
E4600 and E5600 Command Modules	2-14

Chapter 3: DRIVE MODULE SITE PREPARATION

Area Requirements.....	3-2
Weights.....	3-2
Dimensions	3-4
Shipping Carton Dimensions	3-5
Airflow.....	3-6
Environmental Requirements	3-7
Power Requirements.....	3-8
Power Cord Routing.....	3-9
Site Wiring	3-12
Interface Cables and Connections.....	3-13
FC-1 10x and FC-1 14x Drive Modules.....	3-13
FC-2 14x Drive Module.....	3-15

Chapter 4: ARRAY MODULE SITE PREPARATION

Area Requirements.....	4-2
Weights.....	4-2
Dimensions	4-4
Shipping Carton Dimensions	4-5
Airflow.....	4-6
Environmental Requirements	4-7
Power Requirements.....	4-8
Power Cord Routing.....	4-9
Site Wiring	4-11
Interface Cables and Connections.....	4-12

List of Figures

Chapter 1: 72-INCH CABINET SITE PREPARATION

Figure 1-1. 72-inch Cabinet	1-2
Figure 1-2. Cabinet Area Requirements	1-4
Figure 1-3. Cabinet Dimensions	1-6
Figure 1-4. Cabinet AC Distribution	1-9
Figure 1-5. Cabinet Ladder Cord	1-10
Figure 1-6. Types of 72-Inch Cabinet Power Cords and Receptacles	1-11

Chapter 2: COMMAND MODULE SITE PREPARATION

Figure 2-1. Command Module Dimensions	2-4
Figure 2-2. Command Module Airflow	2-5
Figure 2-3. Redundant Command Module AC Power Connections	2-9
Figure 2-4. Types of 72-Inch Cabinet AC Power Cords and Receptacles	2-10
Figure 2-5. Optical and Copper GBICs	2-12
Figure 2-6. SFP Transceiver and Fiber Optic Cable	2-14

Chapter 3: DRIVE MODULE SITE PREPARATION

Figure 3-1. FC-1 10x Drive Module Dimensions	3-4
Figure 3-2. FC-1 14x and FC-2 14x Drive Module Dimensions	3-5
Figure 3-3. Drive Module Airflow	3-6
Figure 3-4. Redundant AC Power Connections to Drive Modules	3-10
Figure 3-5. Types of 72-Inch Cabinet AC Power Cords and Receptacles	3-11
Figure 3-6. Optical and Copper GBICs	3-13
Figure 3-7. SFP Transceiver and Fiber Optic Cable	3-15

Chapter 4: ARRAY MODULE SITE PREPARATION

Figure 4-1. E2400 10x Array Module Dimensions	4-4
Figure 4-2. E2400 14x Array Module Dimensions	4-5
Figure 4-3. Array Module Airflow	4-6
Figure 4-4. Redundant AC Power Connections to Array Modules	4-9
Figure 4-5. Types of 72-Inch Cabinet AC Power Cords and Receptacles	4-10
Figure 4-6. Optical and Copper GBICs	4-12

List of Tables

Chapter 1: 72-INCH CABINET SITE PREPARATION

Table 1-1. Cabinet, Crate, and Module Weights	1-5
Table 1-2. Cabinet Environmental Requirements	1-7
Table 1-3. Power Requirements	1-8

Chapter 2: COMMAND MODULE SITE PREPARATION

Table 2-1. E4400 Command Module Weight	2-2
Table 2-2. E4600 Command Module Weight	2-3
Table 2-3. E5600 Command Module Weight	2-3
Table 2-4. Command Module Shipping Carton Dimensions	2-4
Table 2-5. Command Module Environmental Requirements	2-6
Table 2-6. Command Module Heat Dissipation	2-7
Table 2-7. Command Module Power Requirements	2-8
Table 2-8. E4400 Command Module Fibre Channel Interface Cables	2-13
Table 2-9. E4600 Command Module Fibre Channel Host and Drive Interface Cables	2-14
Table 2-10. E5600 Command Module Fibre Channel Host and Drive Interface Cables	2-15

Chapter 3: DRIVE MODULE SITE PREPARATION

Table 3-1. FC-1 10x Drive Module Weight	3-2
Table 3-2. FC-1 14x Drive Module Weight	3-3
Table 3-3. FC-2 14x Drive Module Weight	3-3
Table 3-4. Drive Module Shipping Carton Dimensions	3-5
Table 3-5. Drive Module Environmental Requirements	3-7
Table 3-6. Drive Module Heat Dissipation	3-7
Table 3-7. FC-1 10x Drive Module Power Requirements	3-8
Table 3-8. FC-1 14x Drive Module Power Requirements	3-8
Table 3-9. FC-2 14x Drive Module Power Requirements	3-9
Table 3-10. FC-1 10x and FC-1 14x Drive Module Fibre Channel Interface Cables	3-14
Table 3-11. FC-2 14x Drive Module Fibre Channel Interface Cables	3-15

Chapter 4: ARRAY MODULE SITE PREPARATION

Table 4-1. E2400 10x Array Module Weight	4-2
Table 4-2. E2400 14x Array Module Weight	4-3
Table 4-3. Array Module Shipping Carton Dimensions	4-5
Table 4-4. Array Module Environmental Requirements	4-7
Table 4-5. Array Module Heat Dissipation	4-7
Table 4-6. E2400 10x Array Module Power Requirements	4-8
Table 4-7. E2400 14x Array Module Power Requirements	4-8
Table 4-8. E2400 10x and E2400 14x Array Module Fibre Channel Interface Cables	4-13

72-Inch Cabinet Site Preparation

This chapter contains essential site preparation information for the 72-inch cabinet that you will use to determine installation, service, and operating floor space requirements; heating and air conditioning specifications; and voltage and power requirements.

Cabinet Features

The rackmount cabinet ([Figure 1-1](#)) has a detachable back door and standard Electronic Industry Association (EIA) rails, which provide mounting holes for installing 19-inch wide devices. The cabinet has four roller casters and four adjustable guides (located beneath the cabinet) for moving and leveling the cabinet during installation and relocation. Newer models of this cabinet have interface cable access holes on the top and a removable stability foot that prevents the cabinet from tipping when it is moved.

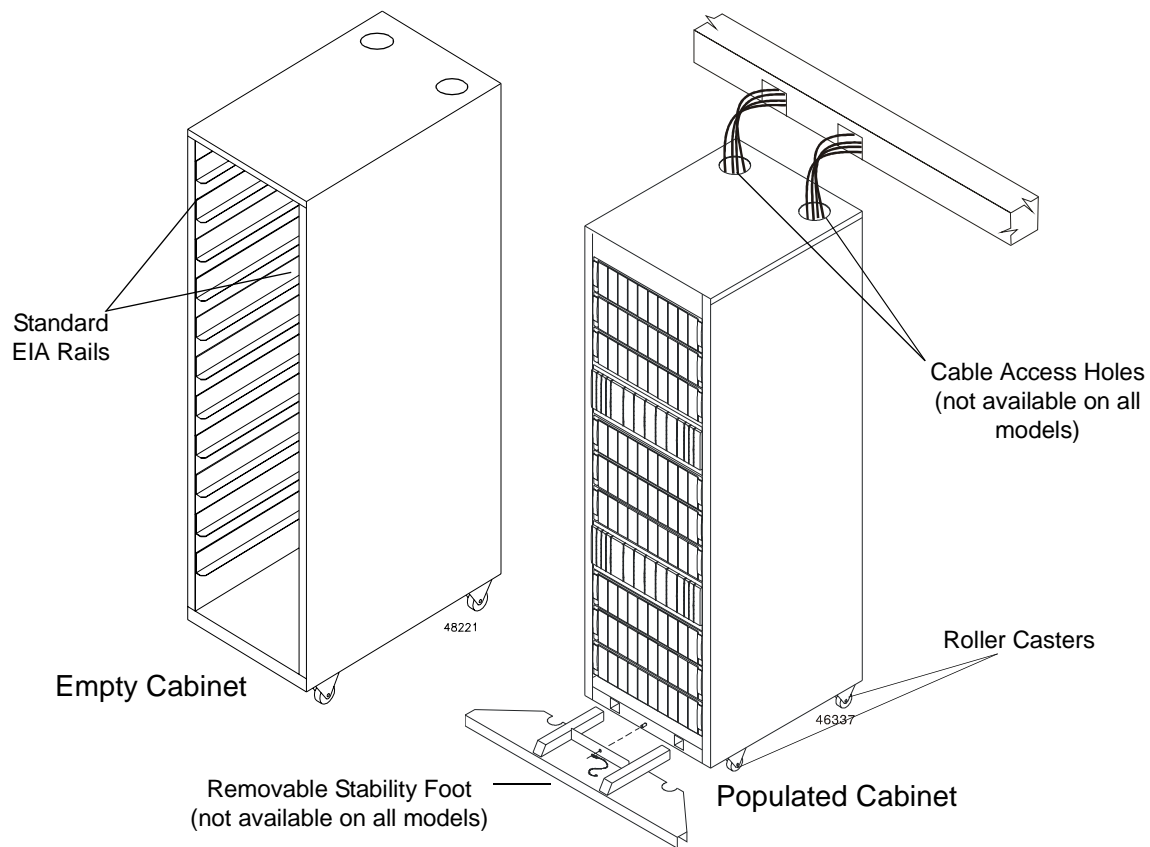

Figure 1-1 72-inch Cabinet

You can customize the cabinet to meet your data storage needs, based on performance, capacity, and availability requirements. The cabinet contains two AC power distribution boxes and can support a combination of twelve modules. The cabinet will ship with a maximum of three command modules installed.

- The command module is a rackmount unit containing two controllers, a battery, redundant cooling fans and power supplies.
- The array module may contain up to fourteen drives, redundant fans and power supplies, and two controllers.
- The drive module may contain up to fourteen drives, redundant fans and power supplies, and an Environmental Service Module (ESM).

Area Requirements

The floor area at the installation site must provide enough stability to support the weight of the cabinet and installed devices, sufficient space to install and service the cabinet and components, and sufficient ventilation to provide a free flow of air to the cabinet. Airflow in the cabinet is from the front to back. See [Figure 1-2](#) for more information.

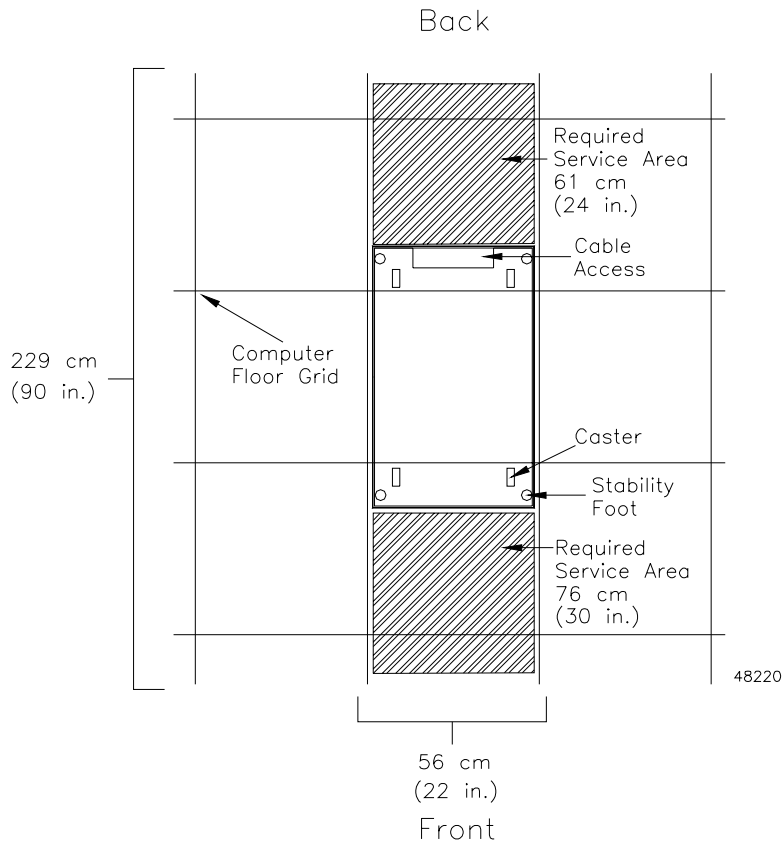

Figure 1-2 Cabinet Area Requirements

Weights

The total weight depends on the type and quantity of modules installed in the cabinet. [Table 1-1](#) lists the overall weight of the cabinet, plus the maximum weight for each module. Use these weights to estimate the total weight of your system, based on the number of modules installed in the cabinet.

Table 1-1 Cabinet, Crate, and Module Weights

Cabinets and Modules		Unit Weight
Cabinet	Empty	123.0 kg (270.0 lb)
Pallet and Packaging ¹	Empty	98.0 kg (215.0 lb)
E2400 10x Array Module Deskside, Low Profile (LP) drives ²	Maximum	50.8 kg (112 lb)
E2400 10x Array Module Deskside, Half Height (HH) drives ³	Maximum	54.4 kg (120.0 lb)
E2400 10x Array Module Rackmount, LP drives	Maximum	38.9 kg (86.4 lb)
E2400 10x Array Module Rackmount, HH drives	Maximum	42.3 kg (94.0 lb)
E2400 14x Array Module Deskside, LP drives	Maximum	52.84 kg (116.5 lb)
E2400 14x Array Module Rackmount, LP drives	Maximum	40.95 kg (90.5 lb)
FC-1 10x Drive Module Deskside, LP drives	Maximum	44.5 kg (98.0 lb)
FC-1 10x Drive Module Deskside, HH drives	Maximum	47.8 kg (105.0 lb)
FC-1 10x Drive Module Rackmount, LP drives	Maximum	38.3 kg (84.4 lb)
FC-1 10x Drive Module Deskside, HH drives	Maximum	41.7 kg (92.0 lb)
FC-1 14x Drive Module Rackmount, LP drives	Maximum	40.95 kg (90.5 lb)
FC-2 14x Drive Module Rackmount, LP drives	Maximum	30.87 kg (68 lb)
E4400 Command Module	Maximum	55.6 kg (122.3 lb)
E4600 or E5600 Command Module	Maximum	43.99 kg (97.0 lb)

¹ Add for international shipments only

² Low-Profile drives

³ Half-Height drives

Dimensions

The cabinet has the following dimensions (Figure 1-3), excluding the removable stability foot:

- **Height** – 183 cm (72 in.)
- **Width** – 56 cm (22 in.)
- **Depth** – 91 cm (36 in.)

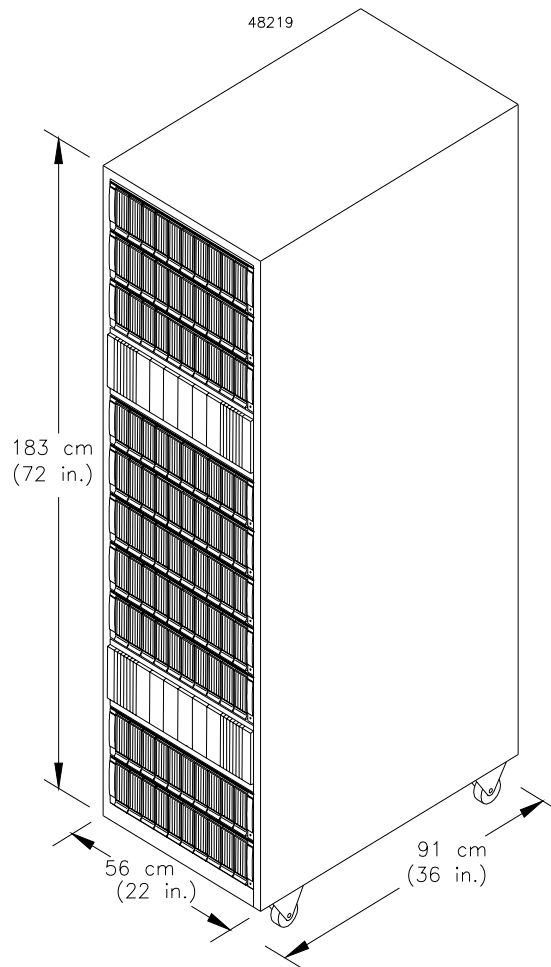

Figure 1-3 Cabinet Dimensions

Environmental Requirements

The cabinet is designed to operate in the environment defined in [Table 1-2](#).

Table 1-2 Cabinet Environmental Requirements

Environment	Requirements			
Altitude	Operating Range	Storage Range	Transit Range	
Below Sea Level	30.5 m (100 ft.)	30.5 m (100 ft.)	30.5 m (100 ft.)	
Above Sea Level	3048 m (10,000 ft.)	3048 m (10,000 ft.)	12,000 m (40,000 ft.)	
Temperature	Operating Range	Storage Range	Transit Range	
Temperature Range	10° C to 35° C (50° F to 104° F)	-10° C to 65° C (140° F to 149° F)	-40° to 65° C (-40° F to 149° F)	
Temperature Change	10° C per hour (21° F per hour)	15° C per hour (31° F per hour)	20° C per hour (42° F per hour)	
Relative Humidity	Operating Range	Storage Range	Transit Range	Maximum Allowed
No Condensation	20% to 80%	10% to 90%	5% to 95%	
Dew Point				28° C (82° F)
Humidity Gradient				10% per hour
Noise	Steady/Non-Steady		Normal Operation	
Level	6.8 bels		65 dBA	
Heat Dissipation¹	Component	Configuration A¹	Configuration B¹	Configuration C¹
	LP Drives ²	1.62 kVA 1601 W 5467 Btu/hr	3.23 kVA 3202 W 10,934 Btu/hr	2.90 kVA 2866 W 9788 Btu/hr
	HH Drives ²	1.69 kVA 1677 W 5727 Btu/hr	3.39 kVA 3354 W 11,454 Btu/hr	3.02 kVA 2988 W 10,205 Btu/hr

¹ These are kVA, W, and Btu calculations for three configurations containing Low-Profile (LP) and Half-Height (HH) drives, including:

- Configuration A contains 1 command module and 5 drive modules
- Configuration B contains 2 command modules and 10 drive modules
- Configuration C contains 3 command modules and 8 drive modules

² LP drives are 1.0 inch tall; HH drives are 1.6 inches tall.

Power Requirements

This section provides information regarding power requirements, AC power distribution box specifications, ladder cord and power cord routing instructions, and site wiring conditions.

The AC power source must provide the correct voltage, current, and frequency specified on the manufacturer's nameplate. [Table 1-3](#) shows the internal AC power requirements for rackmount cabinets.

Table 1-3 Power Requirements

Unit/Component	Requirements			
	Domestic	International		
AC Power	250 VAC, 30 A	230 VAC, 32 A		
AC Plug	NEMA L6-30P, locking plug	IEC 309 locking plug		
Receptacle	6-30R, receptacle	IEC 309 receptacle		
Circuit Breaker	25 A			
Voltage Range	180 to 257 VAC			
Frequency	49 to 50.5 Hz or 59 to 60.6 Hz			
Current (specified frequency)	220 VAC, 50/60 Hz			
		Configuration A ¹	Configuration B ¹	Configuration C ¹
Operational Current	LP Drives ²	7.35 A	14.70 A	13.16 A
	HH Drives ²	7.70 A	15.40 A	13.72 A
Surge Current	LP Drives	10.95 A	21.90 A	22.20 A
	HH Drives	11.45 A	22.90 A	23.00 A

¹ Power specifications for three configurations containing Low-Profile (LP) and Half-Height (HH) drives, including:
 Configuration A contains 1 command module and 5 drive modules
 Configuration B contains 2 command modules and 10 drive modules
 Configuration C contains 3 command modules and 8 drive modules

² LP drives are 1.0 inch tall; HH drives are 1.6 inches tall.

AC Power Distribution Boxes

The cabinet has two identical AC power distribution boxes with two separate power cords (Figure 1-4). Depending on the configuration ordered, each box supports either domestic or international units and includes the following features:

- One domestic plug (NEMA L6-30P, 30 A, 220 VAC) or one international plug (IEC 309, 32 A, 3-pin, 230 VAC)
- One circuit breaker (25 A)
- Two power outlets (IEC 320, 16 A, C-19, filtered individually for international and domestic EMC compliance)
- Support for up to 12 attachments per box (24 per cabinet) using two ladder cables (refer to “Ladder Cords” on page 1-10)

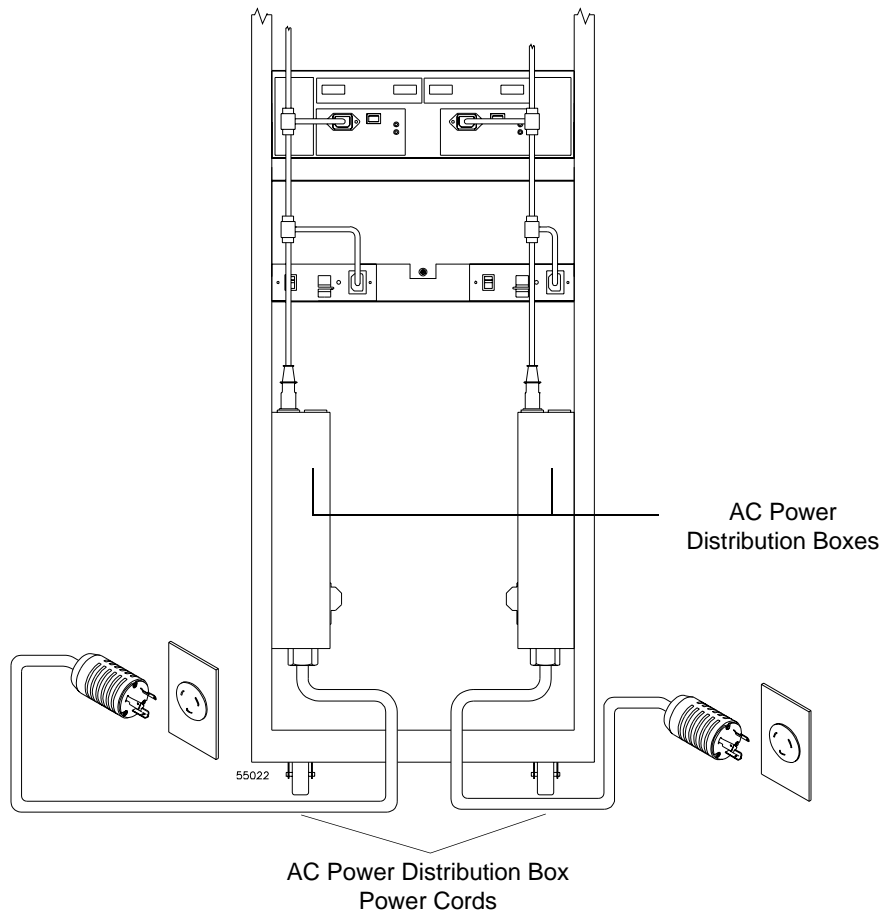

Figure 1-4 Cabinet AC Distribution

Ladder Cords

Each AC power distribution box outlet supports one ladder cord (Figure 1-5) that you can connect to a maximum of six modules. You may connect up to twelve 220/230 VAC modules to each AC power distribution box for a maximum of twenty-four power attachments inside the cabinet.

Although the cabinet may not be fully populated when shipped, the cabinet is shipped with two ladder cords. Each cord has the following specifications:

- **Cord** – 10 A per cord (1.67 A per connection if all are used)
- **Input Connector** – IEC 320, C-19, 16 A, 250 VAC
- **Plugs** – IEC 320, C-14, 10 A, 250 VAC
- **Ladder Step** – 5.25 inches between connections
- **Cord Routing** – Route cords between the mounting rails and side skins of cabinet

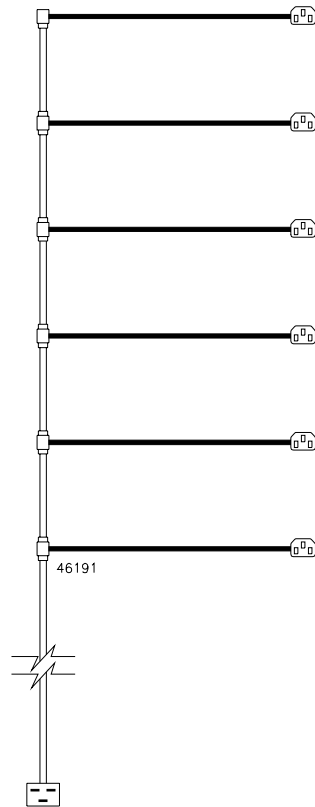

Figure 1-5 Cabinet Ladder Cord

Power Cords and Receptacles

The cabinet is shipped with two power cords: one for domestic (inside USA) use, the other for international (outside USA) use. Each power cord connects to an independent 25 A circuit breaker and an AC power distribution box. The AC power distribution box has two outlets for connecting the power cords from modules installed in the cabinet to an independent power source outside of the cabinet. [Figure 1-6](#) shows these receptacles.

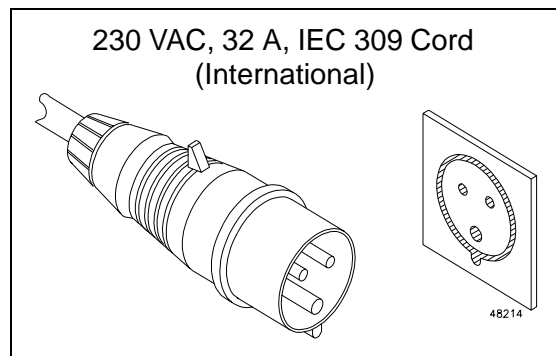
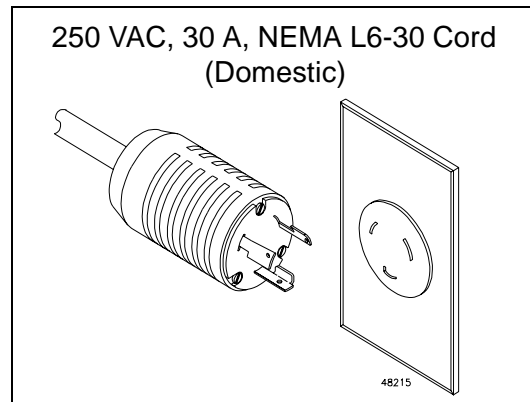
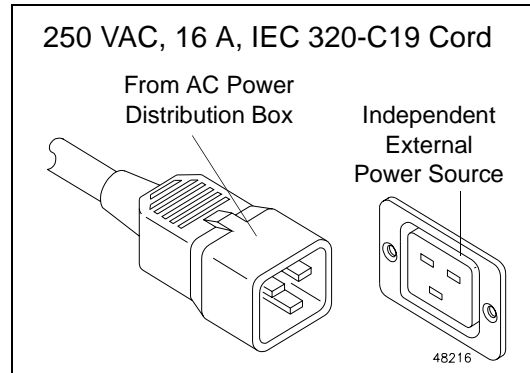

Figure 1-6 Types of 72-Inch Cabinet Power Cords and Receptacles

Site Wiring

The cabinet's AC power distribution boxes use common industrial wiring. Consider the following information when preparing the cabinet installation site:

- **AC power source** – The AC power source must provide the correct voltage, current, and frequency specified on the manufacturer's nameplate.
- **Earth ground** – You must have an earth grounding conductor to the cabinet's power receptacles.
- **Circuit overloading** – Ensure the power circuits and associated circuit breakers provide sufficient power and overload protection. To prevent possible damage to the AC power distribution boxes and other components in the cabinet, use an external, independent power source which is isolated from large switching loads (such as air conditioning motors, elevator motors, and factory loads).
- **Module power distribution** – There are two accessory outlets inside the cabinet for module power distribution. All units attached to these outlets must be auto-ranging between 180 through 257 VAC, 50-60 Hz.
- **Power interruptions** – The cabinet and its modules will withstand the following applied voltage interruptions (with or without an integrated UPS):
 - **Input transient** – 50% of nominal voltage
 - **Duration** – one half cycle
 - **Maximum frequency** – once every ten seconds
- **Power failures** – After a total power failure, the modules within the cabinet will automatically perform a power-up recovery without operator intervention after power is restored.

Command Module Site Preparation

This chapter provides technical specifications and information you will need to prepare a site before installing the E4400, E4600, and the E5600 command modules. This chapter provides information you will use to determine installation, service, and operating floor space requirements; heating and air conditioning specifications; voltage and power requirements; and adapter, module, transceiver, and cabling specifications for interface connectors.

Area Requirements

The floor space at the installation site must provide enough strength to support the weight of the command module and associated equipment, sufficient space to install, operate, and service the command module, and sufficient ventilation to provide a free flow of air to the unit.

Weights

The total weight of the command module depends on the number of components installed. Refer to [Table 2-1](#), [Table 2-2](#), and [Table 2-3](#) for more information.

Table 2-1 E4400 Command Module Weight

Unit	Maximum ¹		Empty Unit ³	
	Unit Weight	Shipping ² Weight	Unit Weight	Shipping ² Weight
Rackmount Command Module	43.99 kg (97.0 lb)	57.2 kg (125.9 lb)	16.1 kg (35.8 lb)	30.8 kg (67.8 lb)
Battery	9.7 kg (21.4 lb)	11.8 kg (26.0 lb)	Not applicable.	
Controller	3.0 kg (6.6 lb)	5.0 kg (11.0 lb)		
Controller Fan	0.9 kg (1.9 lb)	2.3 kg (5.0 lb)		
Power Supply	1.5 kg (3.3 lb)	2.9 kg (6.5 lb)		
Fan Communications Module	1.84 kg (4.06 lb)	2.46 kg (5.44 lb)		
GBIC Minihub	0.567 kg (1.25 lb)	0.712 kg (1.57 lb)		
DB-9 Minihub	0.567 kg (1.25 lb)	0.712 kg (1.57 lb)		

¹ Maximum weight equals a command module with all canisters installed (fully loaded).

² Shipping weight equals the empty or maximum weight of the command module, plus all shipping materials.

³ Empty weight equals a command module with all canisters removed.

Table 2-2 E4600 Command Module Weight

Unit	Maximum ¹		Empty Unit ³	
	Unit Weight	Shipping ² Weight	Weight	Shipping ² Weight
Rackmount Command Module	43.99 kg (97.0 lb)	57.2 kg (125.9 lb)	18.07 kg (39.84 lb)	30.8 kg (67.8 lb)
Battery	10.89 kg (24.0 lb)	12.97 kg (28.6 lb)	Not applicable.	
Controller	3.0 kg (6.6 lb)	5.0 kg (11.0 lb)		
Controller Fan	0.9 kg (1.9 lb)	2.3 kg (5.0 lb)		
Power Supply	1.5 kg (3.3 lb)	2.9 kg (6.5 lb)		
Fan Communications Module	1.84 kg (4.06 lb)	2.9 kg (6.3 lb)		
SFP Minihub	0.567 kg (1.25 lb)	0.6 kg (1.5 lb)		

¹ Maximum weight equals a command module with all canisters installed (fully loaded).

² Shipping weight equals the empty or maximum weight of the command module, plus all shipping materials.

³ Empty weight equals a command module with all canisters removed.

Table 2-3 E5600 Command Module Weight

Unit	Maximum ¹		Empty Unit ³	
	Unit Weight	Shipping ² Weight	Weight	Shipping ² Weight
Rackmount Command Module	43.99 kg (97.0 lb)	57.2 kg (125.9 lb)	18.07 kg (39.84 lb)	30.8 kg (67.8 lb)
Battery	10.89 kg (24.0 lb)	12.97 kg (28.6 lb)	Not applicable.	
Controller	3.0 kg (6.6 lb)	5.0 kg (11.0 lb)		
Controller Fan	0.9 kg (1.9 lb)	2.3 kg (5.0 lb)		
Power Supply	1.5 kg (3.3 lb)	2.9 kg (6.5 lb)		
Fan Communications Module	1.84 kg (4.06 lb)	2.9 kg (6.3 lb)		
SFP Minihub	0.567 kg (1.25 lb)	0.6 kg (1.5 lb)		

¹ Maximum weight equals a command module with all canisters installed (fully loaded).

² Shipping weight equals the empty or maximum weight of the command module, plus all shipping materials.

³ Empty weight equals a command module with all canisters removed.

Dimensions

Command module dimensions are the same for each model (Figure 2-1).

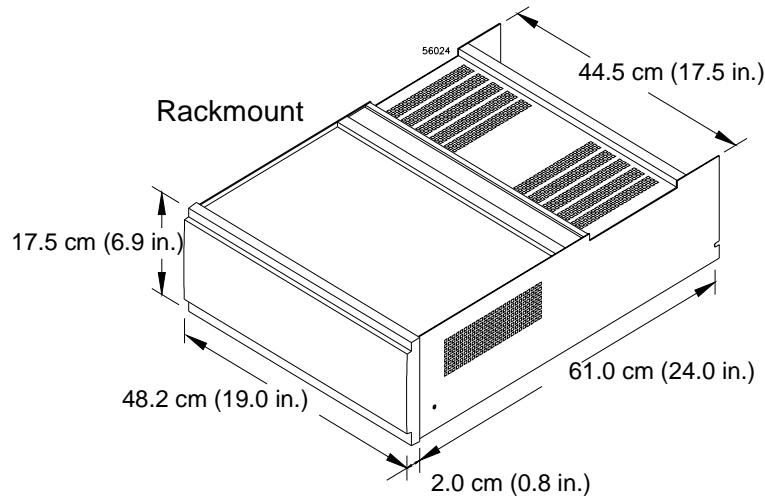

Figure 2-1 Command Module Dimensions

Shipping Carton Dimensions

Shipping carton dimensions include the height of the pallet and are the same for all models (Table 2-4).

Table 2-4 Command Module Shipping Carton Dimensions

Carton Height	Carton Width	Carton Depth
44.4 cm (17.5 in.)	62.2 cm (24.5 in.)	78.7 cm (31.0 in.)

Airflow

For proper ventilation, allow at least 2 feet of clearance in front of and behind the command module (Figure 2-2).

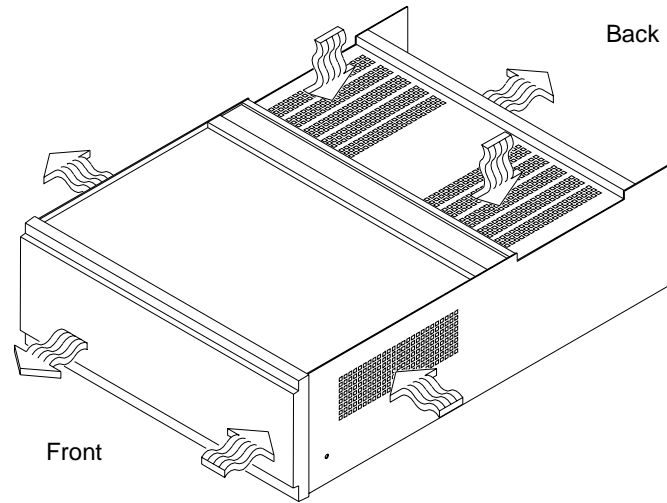

Figure 2-2 Command Module Airflow

Environmental Requirements

The command module is designed to operate in the environment defined in [Table 2-5](#) and [Table 2-6](#).

Table 2-5 Command Module Environmental Requirements

Condition	Parameter	Requirement		
		E4400	E4600	E5600
Temperature	Operating Range	0° C to 43° C (32° F to 109° F)	0° C to 40° C (32° F to 104° F)	
	Maximum Rate of Change	10° C (18° F) per hour		
	Storage Range	-10° C to 65° C (14° F to 149° F)		
	Maximum Rate of Change	15° C (27° F) per hour		
	Transit Range	-40° C to 60° C (-40° F to 140° F)	-40° C to 65° C (-40° F to 149° F)	
	Maximum Rate of Change	20° C (36° F) per hour		
Relative Humidity No condensation	Operating Range	10% to 90%	20% to 80%	
	Storage Range	10% to 93%		
	Transit Range	5% to 95%		
	Maximum Dew Point	26° C (79° F)		
	Maximum Gradient	10% per hour		
Sound	Sound Power	6.5 bels		
	Sound Pressure	65 dBA		
Altitude (Above Sea Level) ¹	Operating and Storage	3000 m (9840 ft.)	3048 (10,000 ft.)	
	Transit	12,000 m (40,000 ft.)		
Altitude (Below Sea Level)	Operating, Storage, and Transit	30.5 m (100 ft.)		

¹ If you plan to operate a command module at altitudes between 1000 m to 3000 m (3280 ft. to 9850 ft.) above sea level, lower the environmental temperature 1.7° C (3.3° F) for every 1000 m (3280 ft.) above sea level.

Table 2-6 Command Module Heat Dissipation

Model	Heat Dissipation
E4400	657.5 Btu/hr (0.1925 kVA or 192.5 W)
E4600	790.0 Btu/hr (0.2333 kVA or 231.0 W)
E5600	786.6 Btu/hr (0.2300 kVA or 230.0 W)

Power Requirements

This section provides information regarding command module AC power requirements, power cord routing instructions, and site wiring conditions.

The AC power source must provide the correct voltage, current, and frequency specified on the manufacturer's nameplate. Internal AC power units for rackmount cabinets must be able to handle the power requirements for these units ([Table 2-7](#)).

Table 2-7 Command Module Power Requirements

Item	Unit of Measure	Requirement
Circuit Breaker	Slow-blow Fuse	3 A per Power Supply
AC Power	Nominal Voltage	90 to 264 VAC
	Frequency	50 to 60 Hz
	Operating Current	1 A ¹
	Maximum Surge Current	2 A ¹

¹ Typical current at 240 VAC, 60 Hz at 0.70 power efficiency, 0.99 power factor.

Power Cord Routing

All modules are shipped with two AC power cords that are appropriate for use in a typical outlet in the destination country. Each power cord connects one of the power supplies in a module to an independent, external power source, such as a wall receptacle or uninterruptible power supply (UPS). If you have a rackmount cabinet with internal power cabling, such as a ladder cable, you do not need these power cords.

A rackmount cabinet can have up to two AC power distribution boxes with separate power cords ([Figure 2-3](#)). To ensure redundancy, each power cord must connect to an independent, external power source. Each AC power distribution box has a ladder cable that runs up the inside of the cabinet and connects to one of the power supplies in each module.

[Figure 2-4 on page 2-10](#) shows the power cords and receptacles for domestic (inside USA) and international use (outside USA).

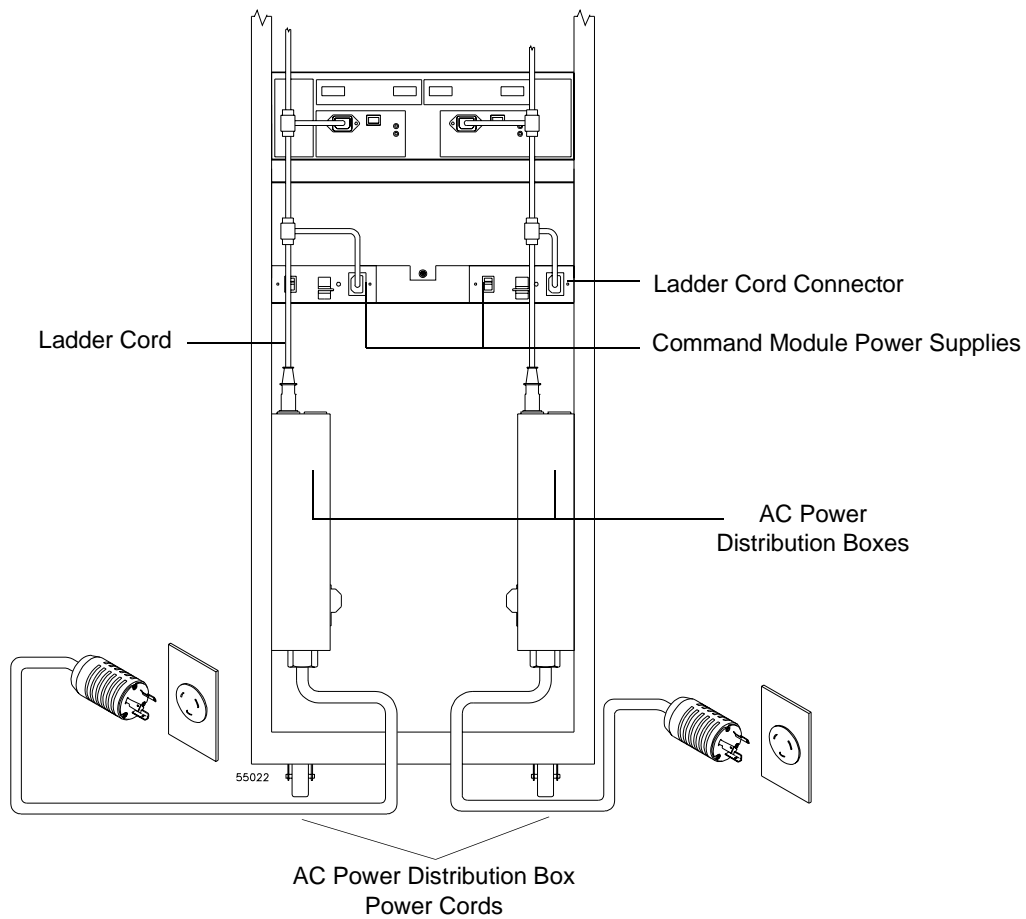

Figure 2-3 Redundant Command Module AC Power Connections

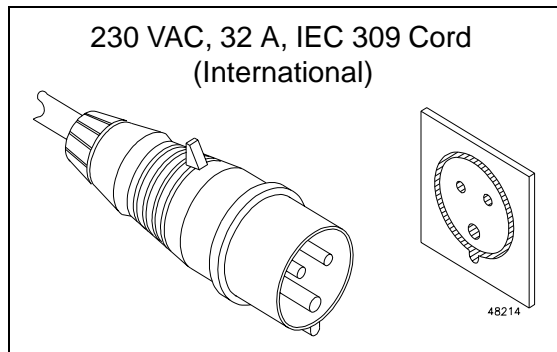
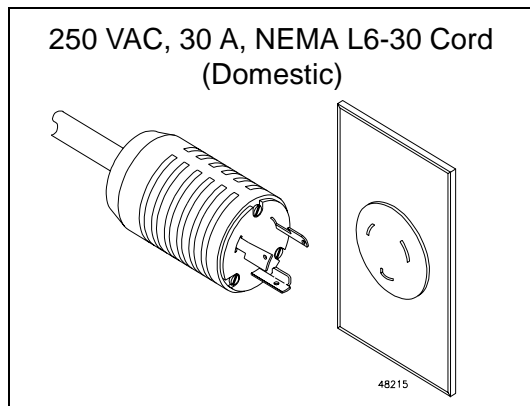
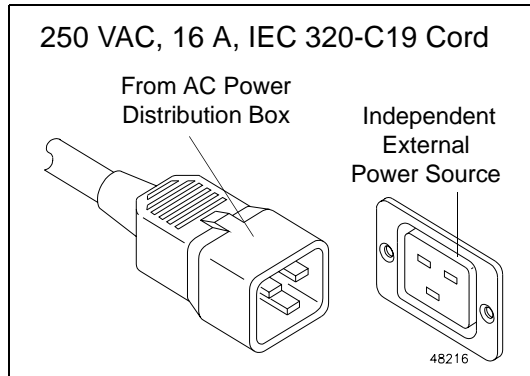

Figure 2-4 Types of 72-Inch Cabinet AC Power Cords and Receptacles

Site Wiring

The command module uses wide-ranging, redundant power supplies that automatically accommodate voltages to the AC power source. The power supplies operate at a range between 90 VAC and 264 VAC, and at a minimum frequency of 50 Hz and a maximum frequency of 60 Hz. The power supplies meet standard voltage requirements for both domestic (inside USA) and international (outside USA) operation. They use standard industrial wiring with line-to-neutral or line-to-line power connections.

Consider the following information when preparing the command module installation site:

- **Earth ground** – The unit must be properly grounded, including an earth ground conductor on the AC power source.
- **Circuit overloading** – Ensure the power circuits and associated circuit breakers in the cabinet and building provide sufficient power and overload protection. To prevent possible damage to the unit, isolate its power source from large switching loads (such as air conditioning motors, elevator motors, and factory loads).
- **Power interruptions** – The command modules will withstand the following applied voltage interruptions (with or without an integrated UPS):
 - **Input transient** – 50% of nominal voltage
 - **Duration** – one half cycle
 - **Frequency** – once every 10 seconds
- **Power failures** – After a total power failure, the unit will automatically perform a power-up recovery sequence without operator intervention after power is restored.

Interface Cables and Connections

This section provides information about command module interface cables, such as GBIC minihubs and SFP transceivers, and their appropriate connections. See [Figure 2-5](#) and [Figure 2-6 on page 2-14](#) for command module interface connector examples.

E4400 Command Module

The E4400 command module supports Fibre Channel connections to both hosts and drive modules. Up to four host minihubs and four drive minihubs, for a maximum of eight connections, can be installed in each command module. The E4400 supports two types of minihubs:

- **GBIC minihub** – contains a pair of connectors for attaching either of the following:
 - **Optical GBIC module** – used with fiber optic cable
 - **Copper GBIC module** – used with copper fiber cable
- **DB-9 minihub** – contains a pair of DB-9 connectors for attaching copper fiber cable

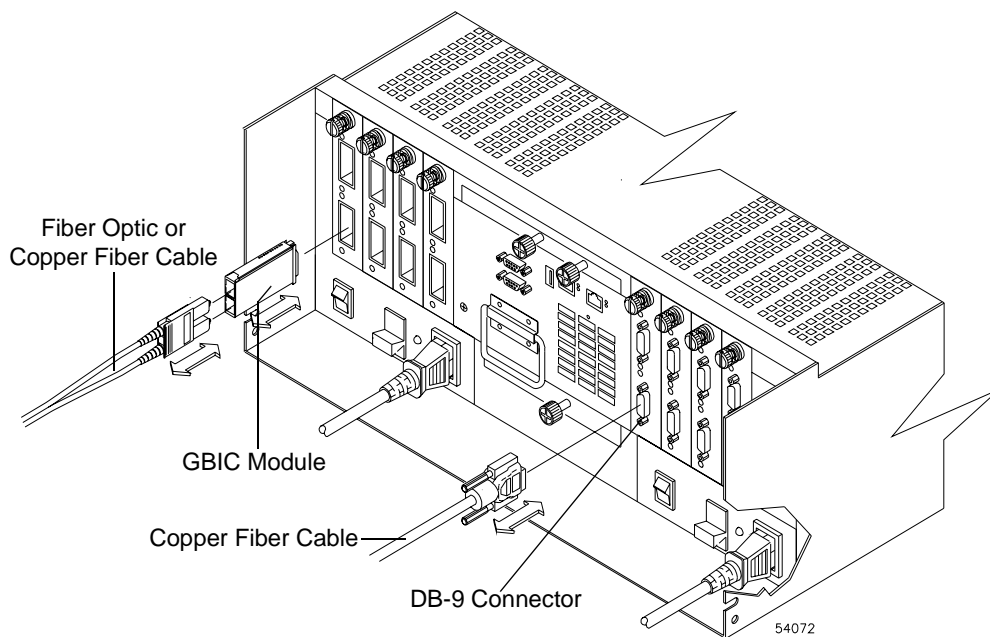

Figure 2-5 Optical and Copper GBICs

If you order optical GBIC connectors, you will need fiber optic cable. If you order copper GBIC minihubs or DB-9 minihubs, you will need copper fiber cable. Refer to [Table 2-8](#) for types and cable lengths available from your local dealer.

Table 2-8 E4400 Command Module Fibre Channel Interface Cables

Descriptions				Order Information	
Cable	Data Rate	Transfer Speed	Maximum Range	Part Number	Length
Fiber optic Multimode, 50micrometer, shortwave laser	100 MB/s	1062.5 Mb/s	0.5 kilometer	006-1086672	2 meter
				006-1086416	3 meter
				006-1086673	5 meter
				006-1086417	10 meter
Copper fiber Shielded, twisted pair, electrical signal	100 MB/s	1062.5 Mb/s	30 meters	006-1086682	2 meter
				006-1086672	3 meter
				006-1086483	5 meter
				006-1086473	10 meter

E4600 and E5600 Command Modules

The E4600 and E5600 command modules support fiber optic connections to both hosts and drive modules. Up to four host minihubs and four drive minihubs can be installed in a command module. Each Small Form-factor Pluggable (SFP) minihub has two connectors, allowing a maximum of sixteen connections. An SFP transceiver (Figure 2-6) attaches to one end of the fiber optic cable and plugs into the SFP minihub, which is connected to the command module. The other end of the cable connects to an optical GBIC module in the drive module.

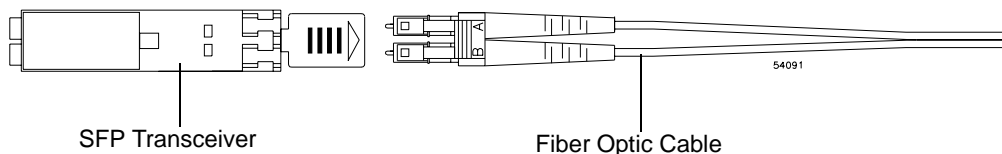

Figure 2-6 SFP Transceiver and Fiber Optic Cable

Refer to Table 2-9 and Table 2-10 for interface connector cable lengths available from your local dealer.

Table 2-9 E4600 Command Module Fibre Channel Host and Drive Interface Cables

Descriptions				Order Information	
Cable	Data Rate	Transfer Speed	Maximum	Part Number	Length
Fiber optic 50/125UM LC/LC	At least 200 MB/s	At least 2125 Mb/s	.03 kilometer	006-1086713	2 meter
				006-1086714	3 meter
				006-1086715	5 meter
				006-1086716	10 meter
				006-1086717	25 meter
				006-1086718	50 meter
Fiber optic 50/125UM SC/LC	100 MB/s	1062.5 Mb/s	0.5 kilometer	006-1086723	2 meter
				006-1086724	3 meter
				006-1086725	5 meter
				006-1086726	10 meter
				006-1086727	25 meter
				006-1086728	50 meter

Table 2-10 E5600 Command Module Fibre Channel Host and Drive Interface Cables

Descriptions				Order Information	
Cable	Data Rate	Transfer Speed	Maximum	Part Number	Length
Fiber optic 50/125 um LC/LC	At least 200 MB/s	At least 2125 Mb/s	300 kilometer	006-1086713	2 meter
				006-1086714	3 meter
				006-1086715	5 meter
				006-1086716	10 meter
				006-1086717	25 meter
				006-1086718	50 meter

Drive Module Site Preparation

This chapter provides technical specifications and information you will need to prepare a site before installing a FC-1 10x, FC-1 14x, or FC-2 14x drive module. This chapter provides information you will use to determine installation, service, and operating floor space requirements; heating and air conditioning specifications; voltage and power requirements; and adapter, module, transceiver, and cabling specifications for interface connectors.

Area Requirements

The floor space at the installation site must provide enough strength to support the weight of the drive module and associated equipment, sufficient space to install, operate, and service the drive module, and sufficient ventilation to provide a free flow of air to the unit.

Weights

The total weight of the drive module depends on the number of components installed. Refer to [Table 3-1](#), [Table 3-2](#), and [Table 3-3](#) for more information.

Table 3-1 FC-1 10x Drive Module Weight

Unit	Weight		
	Maximum Unit ¹	Empty Unit ²	Shipping ³
Drive Module Deskside Low Profile (LP) drives ⁴	44.5 kg (98.0 lb)	23.6 kg (52.0 lb)	59.0 kg (130.0 lb)
Drive Module Deskside Half Height (HH) drives ⁵	47.8 kg (105.0 lb)	23.6 kg (52.0 lb)	62.4 kg (137.0 lb)
Drive Module Rackmount LP drives	38.3 kg (84.4 lb)	12.7 kg (28.0 lb)	43.5 kg (96.0 lb)
Drive Module Rackmount HH drives	41.7 kg (92.0 lb)	12.7 kg (28.0 lb)	47.0 kg (103.6 lb)
LP Drive, 18 GB or 36 GB	1.06 kg (2.34 lb)	Not applicable.	
HH Drive, 36 GB or 73 GB	1.4 kg (3.08 lb)		
ESM	1.7 kg (3.8 lb)		
Power Supply	2.3 kg (5.0 lb)		
Fan	1.0 kg (2.3 lb)		

¹ Maximum weight equals a drive module with all canisters installed (fully loaded).

² Empty weight equals a drive module with all canisters removed.

³ Shipping weight equals the maximum weight of the drive module, plus all shipping material.

⁴ Low-Profile drives.

⁵ Half-Height drives.

Table 3-2 FC-1 14x Drive Module Weight

Unit	Weight	
	Maximum Unit	Shipping ³
Drive Module Rackmount Low Profile (LP) drives	40.95 kg (90.5 lb) ¹	47.25 kg (105.0 lb)
Drive Module Drive-ready Rackmount LP drives	30.5 kg (66.4 lb) ²	37.44 kg (83.2 lb)
LP Drive, 18 GB or 36 GB	1.0 kg (2.2 lb)	
LP Drive, Blank Canisters	0.32 kg (0.72 lb)	
ESM	1.67 kg (3.7 lb)	
Power Supply	2.49 kg (5.5 lb)	
Fan	1.0 kg (2.2 lb)	

¹ Maximum weight equals a drive module with all canisters installed (fully loaded).

² Drive-ready weight equals a drive module with all canisters installed and blank drives (empty).

³ Shipping weight equals the maximum or drive-ready weight of the drive module, plus all shipping material.

Table 3-3 FC-2 14x Drive Module Weight

Unit	Weight	
	Maximum Unit	Shipping ³
Drive Module Rackmount Low Profile (LP) drives	41.77 kg (92 lb) ¹	53.57 kg (118 lb)
Drive Module Drive-ready Rackmount LP drives	30.87 kg (68 lb) ²	42.68 kg (94 lb)
LP Drive, 18 GB or 36 GB	1.0 kg (2.2 lb)	
LP Drive, 73 GB	1.12 kg (2.46 lb)	
LP Drive, Blank Canisters	0.32 kg (0.72 lb)	0.78 kg (1.72 lb)
ESM	1.59 kg (3.7 lb)	2.04 kg (4.5 lb)
Power Supply	2.45 kg (5.39 lb)	3.56 kg (7.39 lb)
Fan	1.01 kg (2.23 lb)	1.92 kg (4.23 lb)

¹ Maximum weight equals a drive module with all canisters installed (fully loaded).

² Drive-ready weight equals a drive module with all canisters installed and blank drives (empty).

³ Shipping weight equals the maximum or drive-ready weight of the drive module, plus all shipping material.

Dimensions

Drive module dimensions for each model differ slightly. See [Figure 3-1](#) and [Figure 3-2](#) for model descriptions.

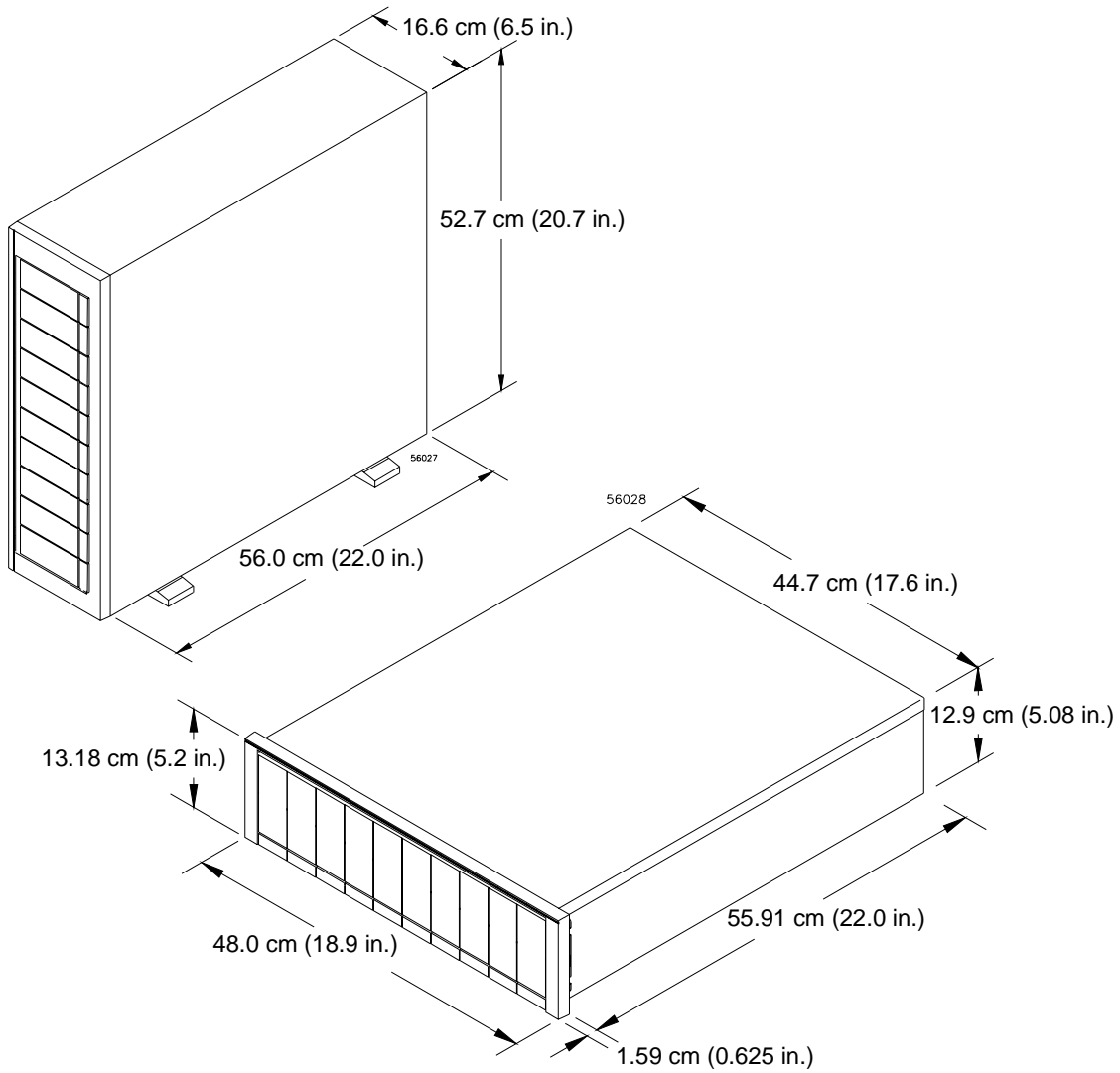

Figure 3-1 FC-1 10x Drive Module Dimensions

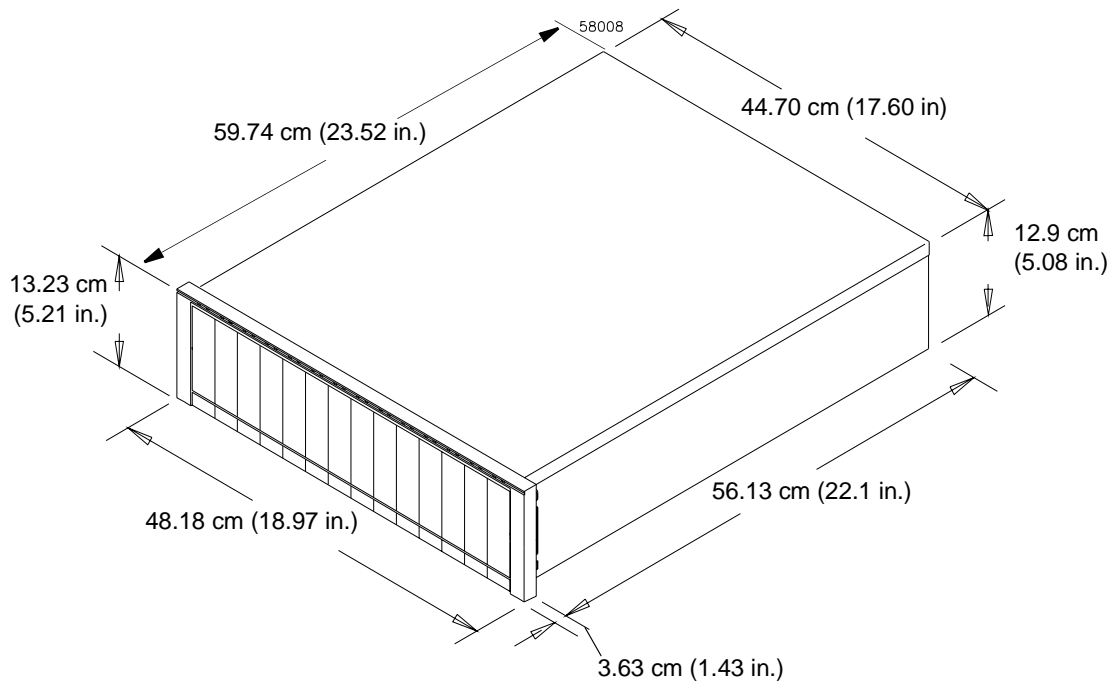

Figure 3-2 FC-1 14x and FC-2 14x Drive Module Dimensions

Shipping Carton Dimensions

Shipping carton dimensions include the height of the pallet ([Table 3-4](#)).

Table 3-4 Drive Module Shipping Carton Dimensions

Model	Carton Height	Carton Width	Carton Depth
FC-1 10x	38.1 cm (15.0 in.)	61.4 cm (24.0 in.)	83.2 cm (32.7 in.)
FC-1 14x and FC-2 14x	44.45 cm (17.5 in.)	62.23 cm (24.5 in.)	74.93 cm (29.5 in.)

Airflow

For proper ventilation, allow at least 2 feet of clearance in front of and behind the drive module (Figure 3-3).

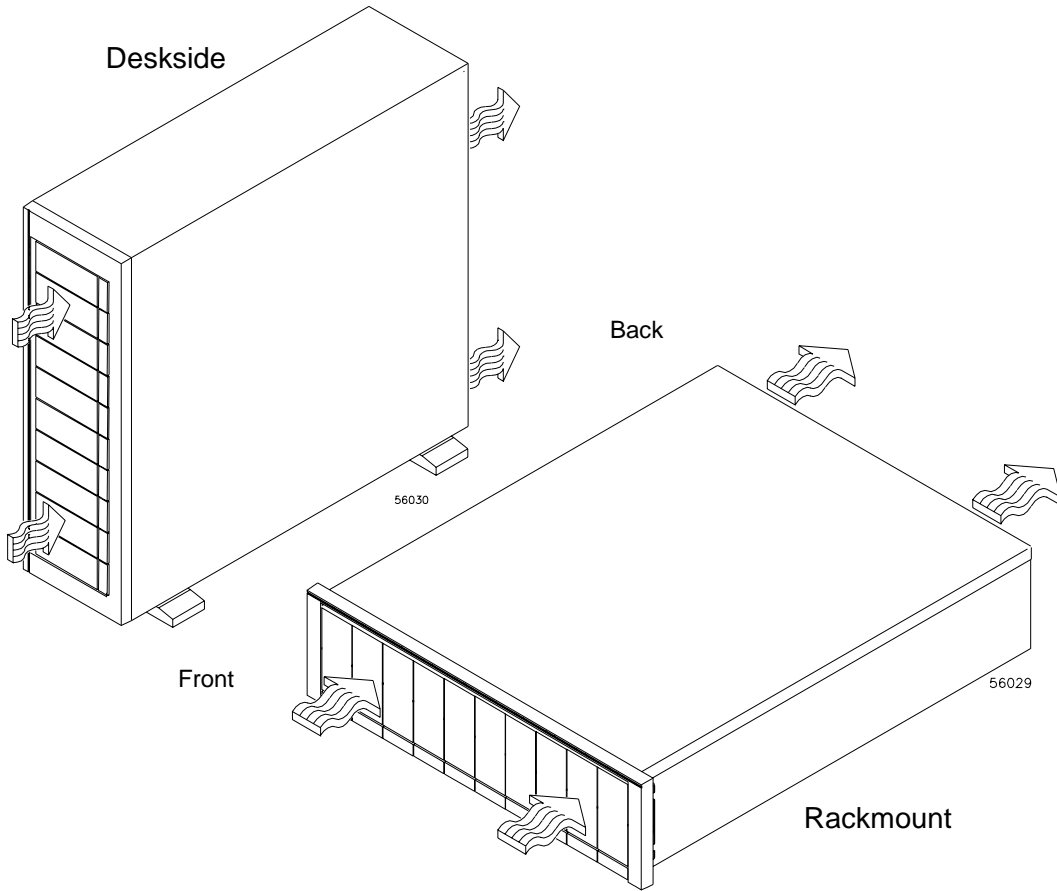

Figure 3-3 Drive Module Airflow

Environmental Requirements

The drive module is designed to operate in the environment defined in [Table 3-5](#) and [Table 3-6 on page 3-7](#).

Table 3-5 Drive Module Environmental Requirements

Condition	Parameter	Requirement
		FC-1 10x, FC-1 14x, and FC-2 14x
Temperature	Operating Range	10° C to 40° C (50° F to 104° F)
	Maximum Rate of Change	10° C (18° F) per hour
	Storage Range	-10° C to 50° C (14° F to 122° F)
	Maximum Rate of Change	15° C (27° F) per hour
	Transit Range	-40° C to 60° C (-40° F to 140° F)
	Maximum Rate of Change	20° C (36° F) per hour
Relative Humidity No condensation	Operating Range	20% to 80%
	Storage Range	10% to 90%
	Transit Range	5% to 95%
	Maximum Dew Point	26° C (79° F)
	Maximum Gradient	10% per hour
Sound	Sound Power	6.0 bels
	Sound Pressure	60 dBA
Altitude (Above Sea Level) ¹	Operating and Storage	3000 m (9840 ft.)
	Transit	12,000 m (40,000 ft.)
Altitude (Below Sea Level)	Operating, Storage, and Transit	30.5 m (100 ft.)

¹ If you plan to operate a drive module at altitudes between 1000 m to 3000 m (3280 ft. to 9850 ft.) above sea level, lower the environmental temperature 1.7° C (3.3° F) for every 1000 m (3280 ft.) above sea level.

Table 3-6 Drive Module Heat Dissipation

Model	Low Profile (LP) 18 GB and 36 GB Drives	Half Height (HH) 36 GB and 73 GB Drives
FC-1 10x	1036 Btu/hr (0.306 kVA or 303 W)	1070 Btu/hr (0.33 kVA or 313 W)
FC-1 14x	1050 Btu/hr (0.309 kVA or 306 W)	Not applicable.
FC-2 14x	1084 Btu/hr (0.320 kVA or 317 W)	Not applicable.

Power Requirements

This section provides information regarding drive module AC power requirements, power cord routing instructions, and site wiring conditions.

The AC power source must provide the correct voltage, current, and frequency specified on the manufacturer’s nameplate. Internal AC power units for rackmount cabinets must be able to handle the power requirements for these units. Refer to [Table 3-7](#), [Table 3-8](#), and [Table 3-9 on page 3-9](#) for more information.

Table 3-7 FC-1 10x Drive Module Power Requirements

Item	Unit of Measure	Requirement	
Circuit Breaker	Slow-blow Fuse	10 A per Power Supply	
AC Power		Low Range	High Range
	Nominal Voltage	90 to 136 VAC	198 to 264 VAC
	Frequency	50 to 60 Hz	50 to 60 Hz
	Idle Current	3.02 A	1.31 A ¹
	Maximum Operating Current	3.11 A	1.34 A ¹
	Maximum Surge Current (10-drive spin up)	4.70 A	1.92 A ¹

¹ Typical current: 240 VAC, 60 Hz at 0.70 power efficiency, 0.99 power factor.

Table 3-8 FC-1 14x Drive Module Power Requirements

Item	Unit of Measure	Requirement	
Circuit Breaker	Slow-blow Fuse	10 A per Power Supply	
AC Power		Low Range	High Range
	Nominal Voltage	90 to 136 VAC	198 to 264 VAC
	Frequency	50 to 60 Hz	50 to 60 Hz
	Idle Current	2.95 A ¹	1.42 A ²
	Maximum Operating Current	3.03 A ¹	1.46 A ²
	Maximum Surge Current (14-drive spin up)	4.28 A ¹	1.97 A ²

¹ Typical current: 115 V AC, 60 Hz at 0.72 power efficiency, 0.99 power factor.

² Typical current: 230 V AC, 60 Hz at 0.72 power efficiency, 0.99 power factor.

Table 3-9 FC-2 14x Drive Module Power Requirements

Item	Unit of Measure	Requirement	
Circuit Breaker	Slow-blow Fuse	10 A per Power Supply	
AC Power		Low Range	High Range
	Nominal Voltage	90 to 136 VAC	198 to 264 VAC
	Frequency	50 to 60 Hz	50 to 60 Hz
	Idle Current	2.93 A ¹	1.27 A ²
	Maximum Operating Current	3.18 A ¹	1.37 A ²
	Maximum Surge Current	5.85 A ¹	2.36 A ²

¹ Typical current: 100 V AC, 60 Hz at 0.73 power efficiency, 0.99 power factor.

² Typical current: 240 V AC, 60 Hz at 0.73 power efficiency, 0.99 power factor.

Power Cord Routing

All modules are shipped with two AC power cords that are appropriate for use in a typical outlet in the destination country. Each power cord connects one of the power supplies in a module to an independent, external power source, such as a wall receptacle or uninterruptible power supply (UPS). If you have a rackmount cabinet with internal power cabling, such as a ladder cable, you do not need these power cords.

Typically, a rackmount cabinet has two AC power distribution boxes with separate power cords (Figure 3-4). To ensure redundancy, each power cord must connect to an independent, external power source. Each AC power distribution box has a ladder cable that runs up the inside of the cabinet and connects to one of the power supplies in each module.

Figure 3-5 on page 3-11 shows the power cords and receptacles for domestic and international use.

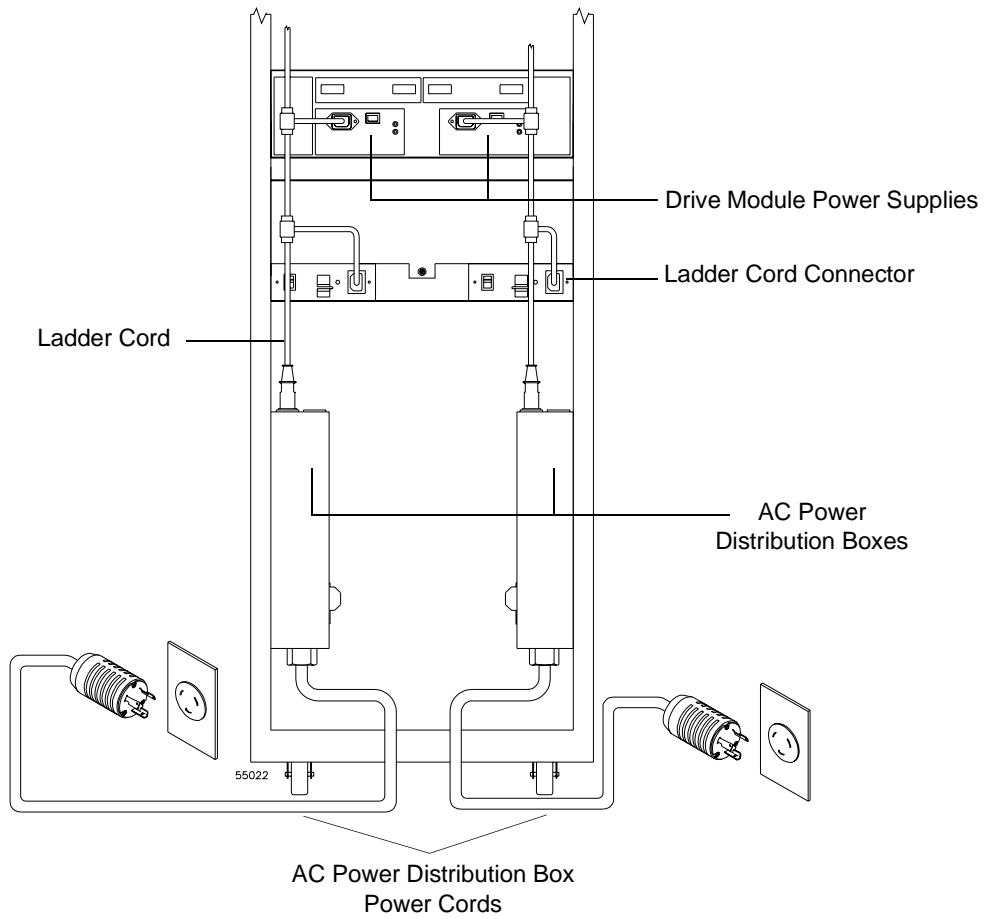

Figure 3-4 Redundant AC Power Connections to Drive Modules

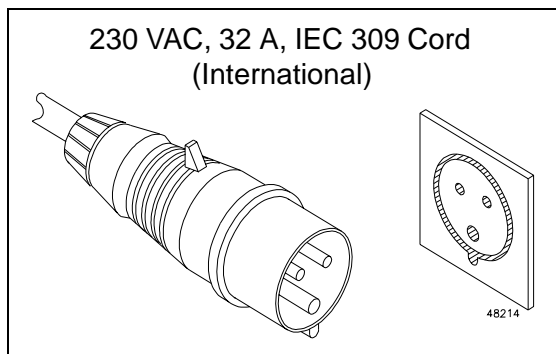
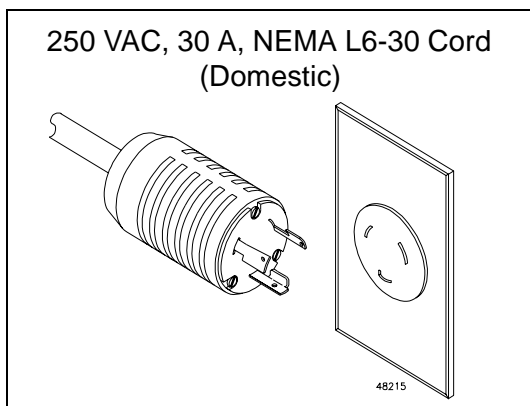
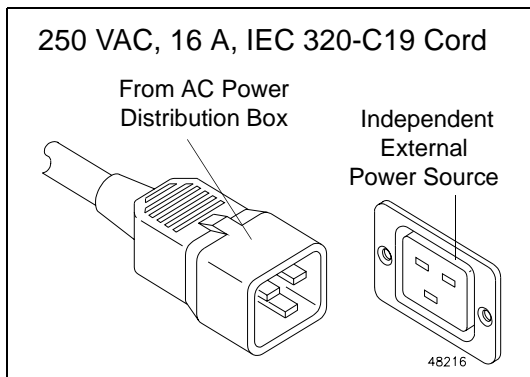

Figure 3-5 Types of 72-Inch Cabinet AC Power Cords and Receptacles

Site Wiring

The drive modules use wide-ranging, redundant power supplies that automatically accommodate voltages to the AC power source. The power supplies operate at a range between 90 VAC and 264 VAC, and at a minimum frequency of 50 Hz and a maximum frequency of 60 Hz. The power supplies meet standard voltage requirements for both domestic (inside USA) and international (outside USA) operation. They use standard industrial wiring with line-to-neutral or line-to-line power connections.

Consider the following information when preparing the drive module installation site:

- **Earth ground** – The unit must be properly grounded, including an earth ground conductor on the AC power source.
- **Circuit overloading** – Ensure the power circuits and associated circuit breakers in the cabinet and building provide sufficient power and overload protection. To prevent possible damage to the unit, isolate its power source from large switching loads (such as air conditioning motors, elevator motors, and factory loads).
- **Power interruptions** – The drive modules will withstand the following applied voltage interruptions (with or without an integrated UPS):
 - **Input transient** – 50% of nominal voltage
 - **Duration** – one half cycle
 - **Frequency** – once every 10 seconds
- **Power failures** – After a total power failure, the unit will automatically perform a power-up recovery sequence without operator intervention after power is restored.

Interface Cables and Connections

This section provides information about drive module interface cables, such as GBIC modules and SFP transceivers, and their appropriate connections.

FC-1 10x and FC-1 14x Drive Modules

The FC-1 10x and FC-1 14x drive modules support Fibre Channel connections to command modules. Each have four GBIC modules; two on each ESM (Figure 3-6). The modules may be fiber optic or copper. The module type depends on what type of drive interface you ordered and what type of cable you will be using to attach the drive module to the command module.

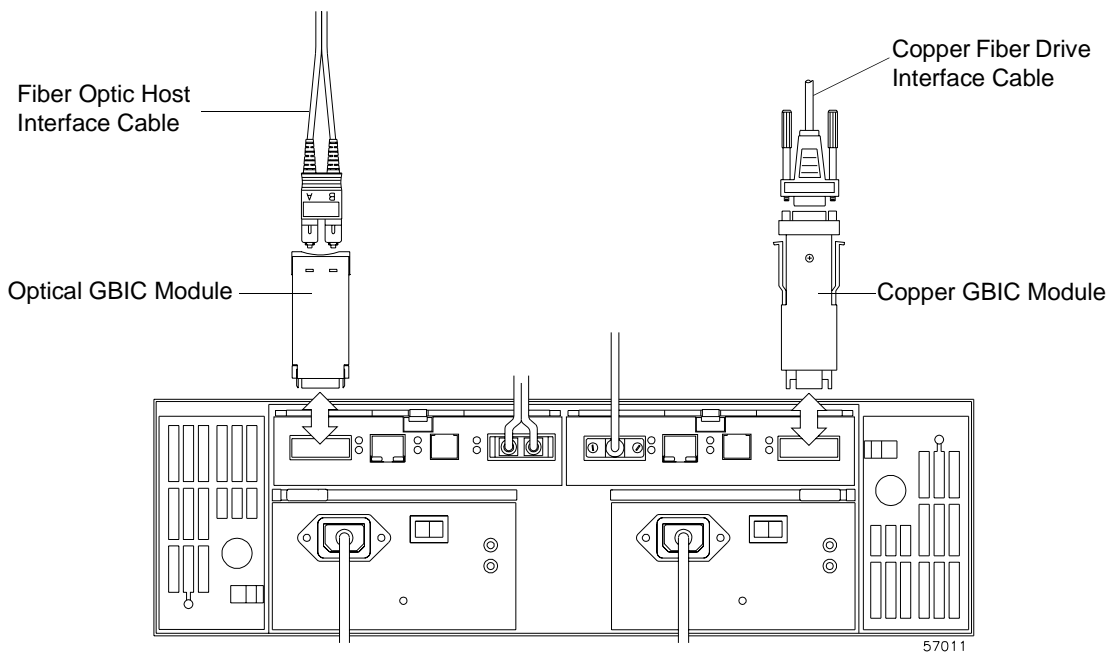

Figure 3-6 Optical and Copper GBICs

If you order optical GBIC modules, you will need fiber optic cable. If you order copper GBIC modules, you will need copper fiber cable. Refer to [Table 3-10](#) for types and cable lengths available from your local dealer.

Table 3-10 FC-1 10x and FC-1 14x Drive Module Fibre Channel Interface Cables

Descriptions				Order Information	
Cable	Data Rate	Transfer Speed	Maximum Range	Part Number	Length
Fiber optic Multi-mode, 50 micrometer, shortwave laser	100 MB/s	1062.5 Mb/s	0.5 kilometer	006-1086672	2 meter
				006-1086416	3 meter
				006-1086673	5 meter
				006-1086417	10 meter
Copper fiber Shielded, twisted pair, electrical signal	100 MB/s	1062.5 Mb/s	30 meters	006-1086682	2 meter
				006-1086672	3 meter
				006-1086483	5 meter
				006-1086473	10 meter
Fiber optic 50/125UM SC/LC	100 MB/s	1062.5 Mb/s	0.5 kilometer	006-1086723	2 meter
				006-1086724	3 meter
				006-1086725	5 meter
				006-1086726	10 meter
				006-1086727	25 meter
				006-1086728	50 meter

FC-2 14x Drive Module

The FC-2 14x drive module supports Fibre Channel connections to command modules. The drive module ships with two ESMs, and each has connectors for two optical Small Form-factor Pluggable (SFP) transceivers (Figure 3-7).

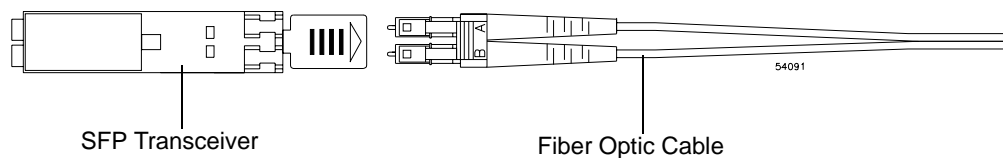

Figure 3-7 SFP Transceiver and Fiber Optic Cable

You will need to order fibre optic cable to connect the modules. Refer to Table 3-11 for interface connector cable lengths available from your local dealer.

Table 3-11 FC-2 14x Drive Module Fibre Channel Interface Cables

Descriptions				Order Information	
Cable	Data Rate	Transfer Speed	Maximum Range	Part Number	Length
Fiber optic 50/125UM LC/LC	At least 200 MB/s	At least 2125 Mb/s	0.3 kilometer	006-1086713	2 meter
				006-1086714	3 meter
				006-1086715	5 meter
				006-1086716	10 meter

Drive Module Site Preparation.

Array Module Site Preparation

This chapter provides technical specifications and information you will need to prepare a site before installing the E2400 10x and E2400 14x array modules. This chapter provides information you will use to determine installation, service, and operating floor space requirements; heating and air conditioning specifications; voltage and power requirements; and adapter, module, transceiver, and cabling specifications for interface connectors.

Area Requirements

The floor space at the installation site must provide enough strength to support the weight of the array module and associated equipment, sufficient space to install, operate, and service the array module, and sufficient ventilation to provide a free flow of air to the unit.

Weights

The total weight of the array module depends on the number of components installed. Refer to [Table 4-1](#) and [Table 4-2](#) for more information.

Table 4-1 E2400 10x Array Module Weight

Unit	Weight		
	Maximum Unit ¹	Empty Unit ²	Shipping ³
Array Module Deskside, Low Profile (LP) drives	50.8 kg (112 lb)	23.6 kg (52.0 lb)	59.0 kg (130.1 lb)
Array Module Deskside, Half Height (HH) drives	54.4 kg (120.0 lb)	23.6 kg (52.0 lb)	62.6 kg (138.1 lb)
Array Module Rackmount, LP drives	38.9 kg (86.4 lb)	17.8 kg (39.2 lb)	44.1 kg (98.0 lb)
Array Module Rackmount, HH drives	42.3 kg (94.0 lb)	17.8 kg (39.2 lb)	47.5 kg (105.6 lb)
LP Drive, 18 GB or 36 GB	1.06 kg (2.34 lb)		
HH Drive, 36 GB or 73 GB	1.4 kg (3.08 lb)		
Controller	2.2 kg (4.8 lb)		
Power Supply	2.3 kg (5.0 lb)		
Fan	1.0 kg (2.3 lb)		

¹ Maximum weight equals an array module with all canisters installed (fully loaded).

² Empty weight equals an array module with all canisters removed.

³ Shipping weight equals the maximum weight of the array module, plus all shipping materials.

Table 4-2 E2400 14x Array Module Weight

Unit	Weight		
	Maximum Unit ¹	Empty Unit ²	Shipping ³
Array Module Deskside, Low Profile (LP) drives, 18 GB or 36 GB	52.84 kg (116.5 lb)	27.0 kg (59.54 lb)	59.0 kg (130.1 lb)
Array Module Rackmount, LP drives, 18 GB or 36 GB	40.95 kg (90.5 lb)	15.21 kg (33.54 lb)	47.25 kg (105.0 lb)
LP Drive, 18 GB or 36 GB	1.06 kg (2.34 lb)		
Controller	2.2 kg (4.8 lb)		
Power Supply	2.3 kg (5.0 lb)		
Fan	1.0 kg (2.3 lb)		

¹ Maximum weight equals an array module with all canisters installed (fully loaded).

² Empty weight equals an array module with all canisters removed.

³ Shipping weight equals the maximum weight of the array module, plus all shipping materials.

Dimensions

Array module dimensions for each model differ slightly. See [Figure 4-1](#) and [Figure 4-2](#) for model descriptions.

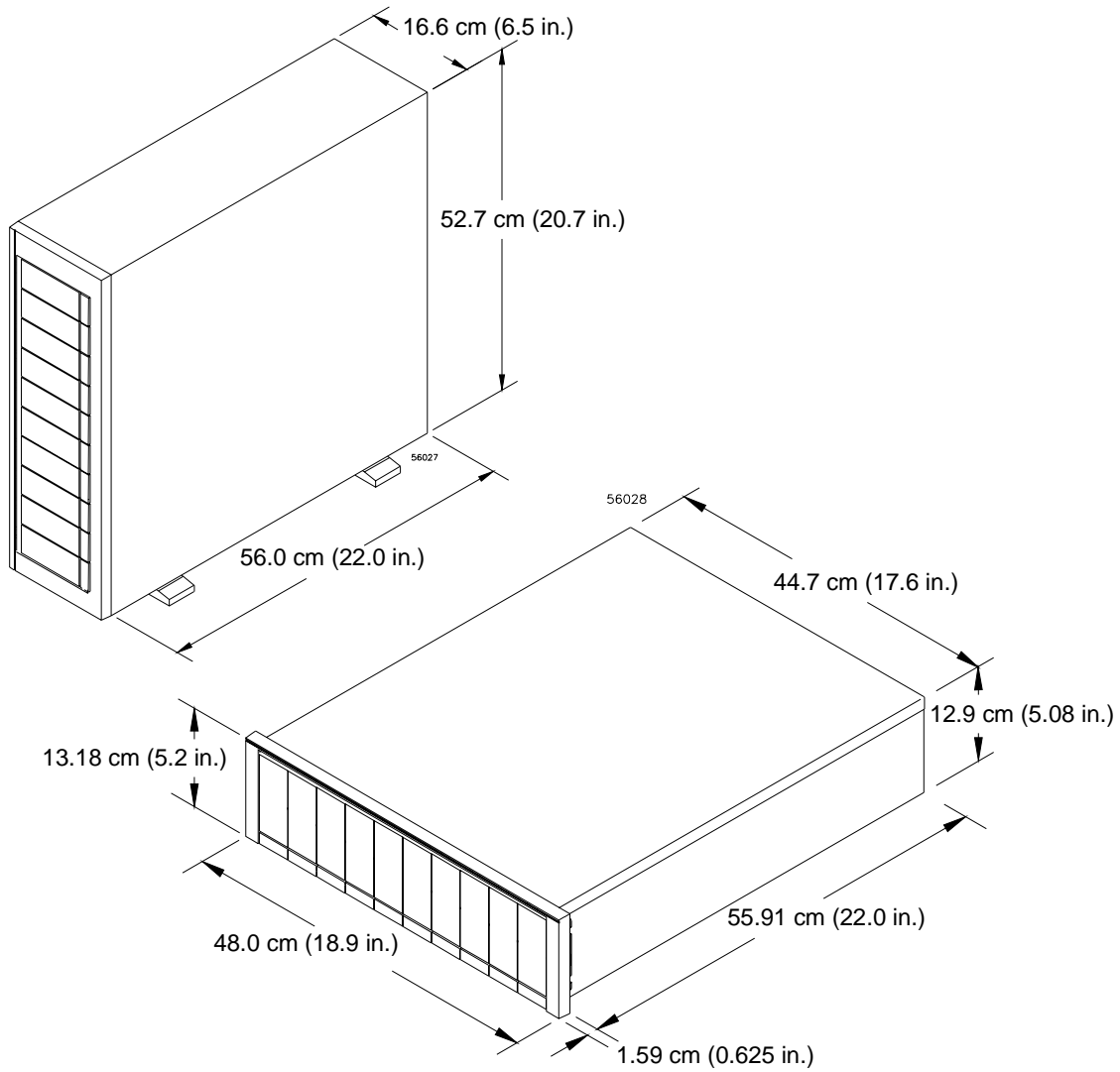

Figure 4-1 E2400 10x Array Module Dimensions

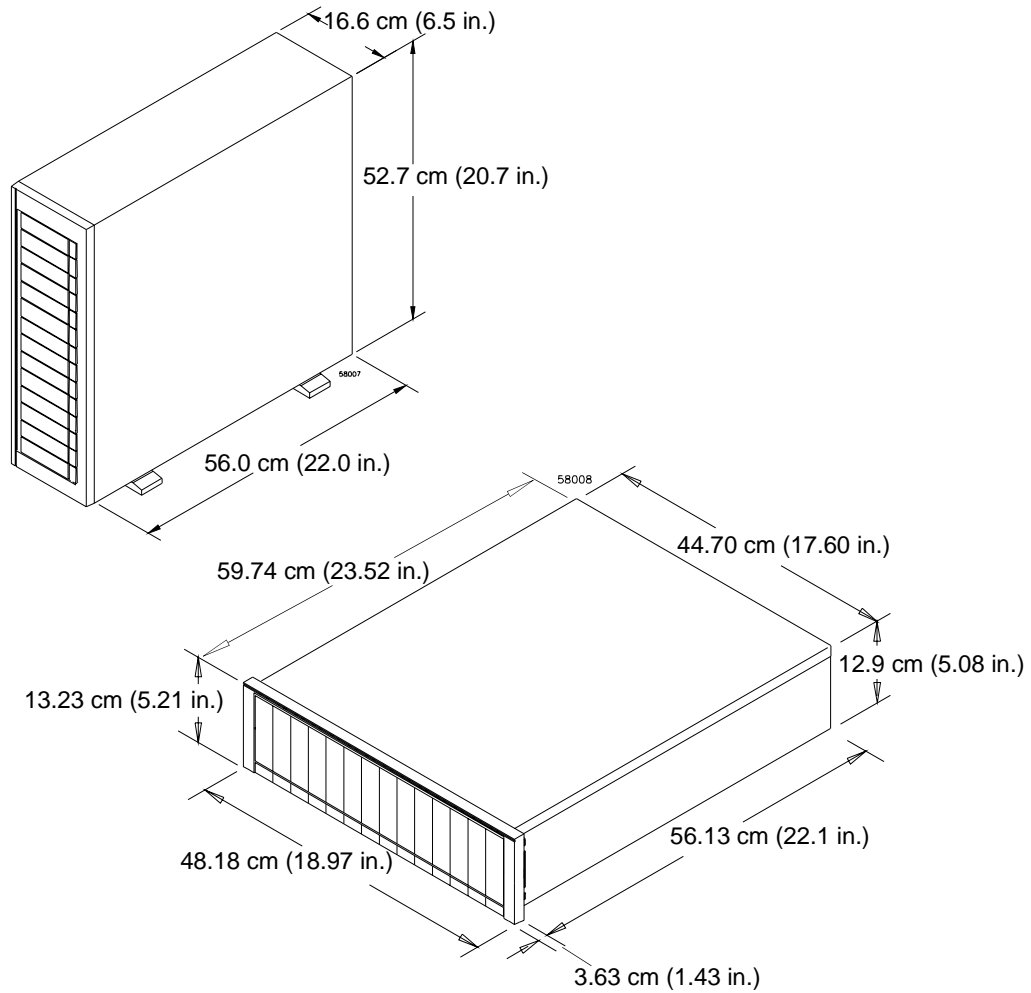

Figure 4-2 E2400 14x Array Module Dimensions

Shipping Carton Dimensions

The shipping carton dimensions include the height of the pallet ([Table 4-3](#)).

Table 4-3 Array Module Shipping Carton Dimensions

Model	Carton Height	Carton Width	Carton Depth
E2400 10x	38.1 cm (15.0 in.)	61.4 cm (24.0 in.)	83.2 cm (32.7 in.)
E2400 14x	44.45 cm (17.5 in.)	62.23 cm (24.5 in.)	74.93 cm (29.5 in.)

Airflow

For proper ventilation, allow at least 2 feet of clearance in front of and behind the array module (Figure 4-3).

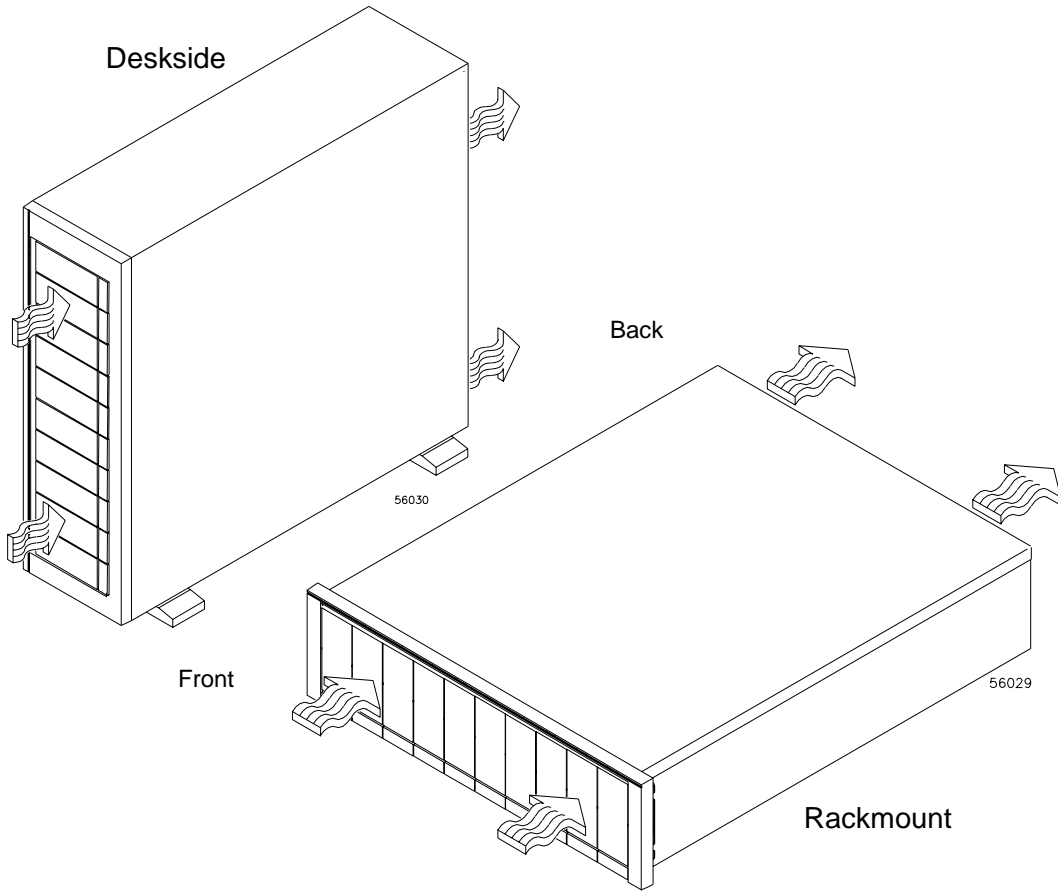

Figure 4-3 Array Module Airflow

Environmental Requirements

The array modules are designed to operate in the environment defined in [Table 4-4](#) and [Table 4-5 on page 4-7](#).

Table 4-4 Array Module Environmental Requirements

Condition	Parameter	Requirement
		E2400 10x and E2400 14x
Temperature	Operating Range	10° C to 40° C (50° F to 104° F)
	Maximum Rate of Change	10° C (18° F) per hour
	Storage Range	-10° C to 50° C (14° F to 122° F)
	Maximum Rate of Change	15° C (27° F) per hour
	Transit Range	-40° C to 60° C (-40° F to 140° F)
	Maximum Rate of Change	20° C (36° F) per hour
Relative Humidity No condensation	Operating Range	20% to 80%
	Storage Range	10% to 90%
	Transit Range	5% to 95%
	Maximum Dew Point	26° C (79° F)
	Maximum Gradient	10% per hour
Sound	Sound Power	6.0 bels
	Sound Pressure	60 dBA
Altitude (Above Sea Level) ¹	Operating and Storage	3000 m (9840 ft.)
	Transit	12,000 m (40,000 ft.)
Altitude (Below Sea Level)	Operating, Storage, and Transit	30.5 m (100 ft.)

¹ If you plan to operate an array module at altitudes between 1000 m to 3000 m (3280 ft. to 9850 ft.) above sea level, lower the environmental temperature 1.7° C (3.3° F) for every 1000 m (3280 ft.) above sea level.

Table 4-5 Array Module Heat Dissipation

Model	Low Profile (LP) 18 GB and 36 GB Drives	Half Height (HH) 36 GB and 73 GB Drives
E2400 10x	1187 Btu/hr (0.35 kVA or 347 W)	1221 Btu/hr (0.37 kVA or 357 W)
E2400 14x	1118 Btu/hr (0.328 kVA or 327 W)	Not applicable.

Power Requirements

This section provides information regarding array module AC power requirements, power cord routing instructions, and site wiring conditions.

The AC power source must provide the correct voltage, current, and frequency specified on the manufacturer’s nameplate. Internal AC power units for rackmount cabinets must be able to handle the power specifications for these units. Refer to [Table 4-6](#) and [Table 4-7](#) for more information.

Table 4-6 E2400 10x Array Module Power Requirements

Item	Unit of Measure	Requirement	
Circuit Breaker	Slow-blow Fuse	10 A per Power Supply	
AC Power		Low Range	High Range
	Nominal Voltage	90 to 136 VAC	198 to 264 VAC
	Frequency	50 to 60 Hz	50 to 60 Hz
	Idle Current	3.39 A	1.45 A ¹
	Maximum Operating Current	3.53 A	1.50 A ¹
	Maximum Surge Current (10-drive spin up)	5.19 A	2.10 A ¹

¹ Typical current at 240 VAC, 60 Hz at 0.70 power efficiency, 0.99 power factor.

Table 4-7 E2400 14x Array Module Power Requirements

Item	Unit of Measure	Requirement	
Circuit Breaker	Slow-blow Fuse	10 A per Power Supply	
AC Power		Low Range	High Range
	Nominal Voltage	90 to 136 VAC	198 to 264 VAC
	Frequency	50 to 60 Hz	50 to 60 Hz
	Idle Current	2.9 A ¹	1.3 A ²
	Maximum Operating Current	3.3 A ¹	1.4 A ²
	Maximum Surge Current (14-drive spin up)	5.9 A ¹	2.4 A ²

¹ Typical voltage: 100 V AC, 60 Hz at 79% power supply efficiency and 0.99 power factor.

² Typical voltage: 240 V AC, 60 Hz at 81% power supply efficiency and 0.92 power factor.

Power Cord Routing

All modules are shipped with two AC power cords that are appropriate for use in a typical outlet in the destination country. Each power cord connects one of the power supplies in a module to an independent, external power source, such as a wall receptacle or uninterruptible power supply (UPS). If you have a rackmount cabinet with internal power cabling, such as a ladder cable, you do not need these power cords.

Typically, a rackmount cabinet has two AC distribution boxes with two separate power cords (Figure 4-4). To ensure redundancy, each power cord must connect to an independent, external power source. Each AC distribution box has a ladder cable that runs up the inside of the cabinet and connects to one of the power supplies in each unit.

Figure 4-5 shows the power cords and receptacles for domestic (inside USA) and international use (outside USA).

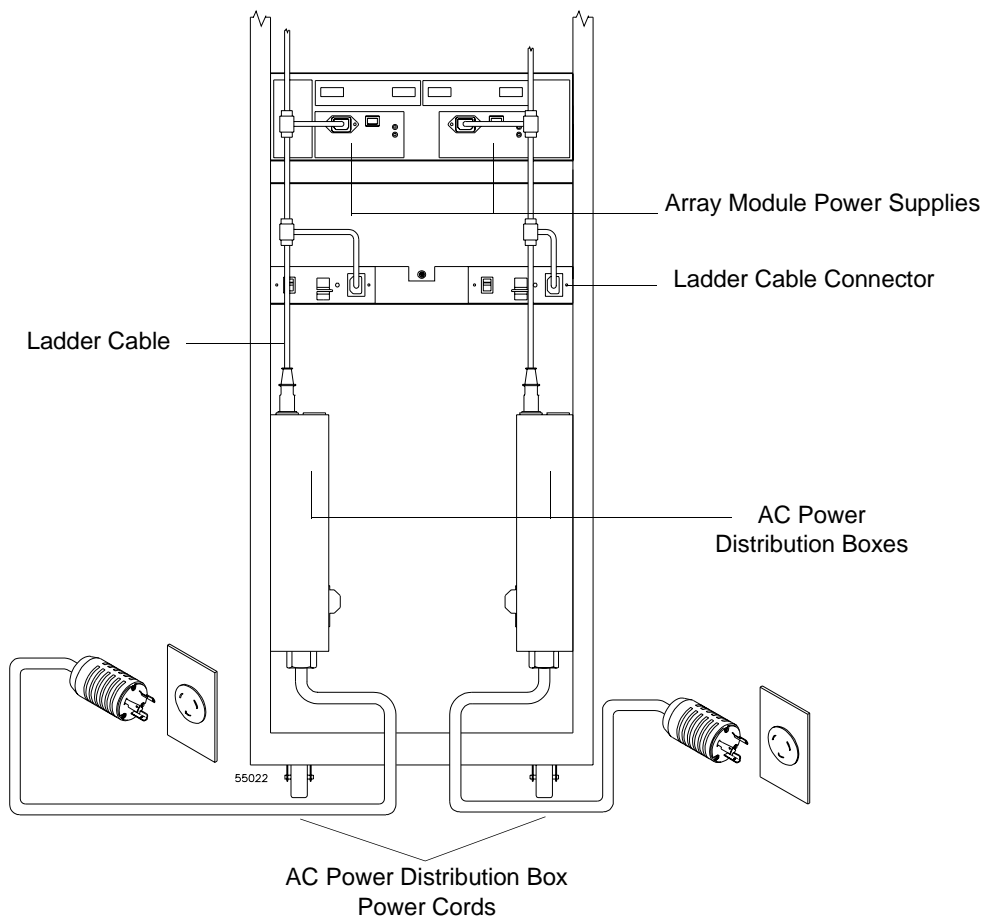

Figure 4-4 Redundant AC Power Connections to Array Modules

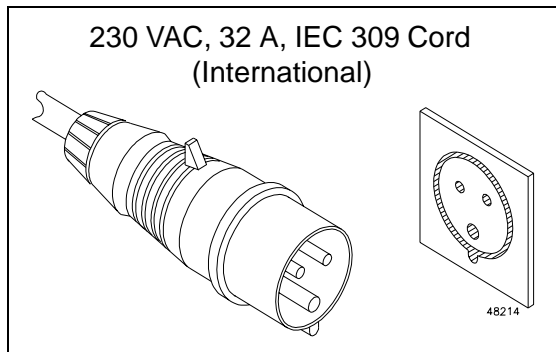
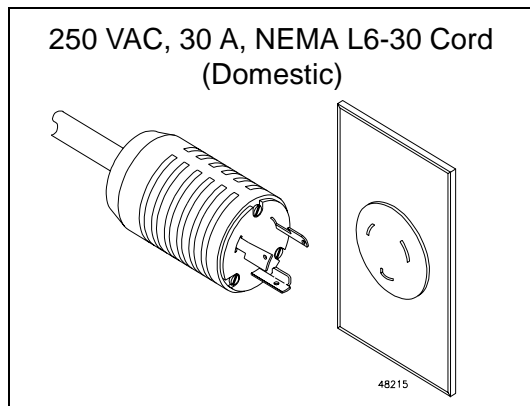
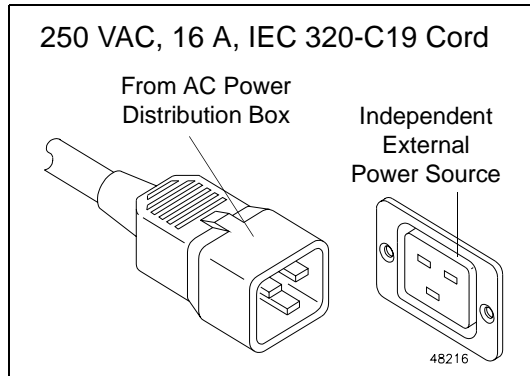

Figure 4-5 Types of 72-Inch Cabinet AC Power Cords and Receptacles

Site Wiring

The array modules use wide-ranging, redundant power supplies that automatically accommodate voltages to the AC power source. The power supplies operate at a range between 90 VAC and 264 VAC, and at a minimum frequency of 50 Hz and a maximum frequency of 60 Hz. The power supplies meet standard voltage requirements for both domestic (inside USA) and international (outside USA) operation. They use standard industrial wiring with line-to-neutral or line-to-line power connections.

Consider the following information when preparing the array module installation site.

- **Earth ground** – The unit must be properly grounded, including an earth ground conductor on the AC power source.
- **Circuit overloading** – Ensure the power circuits and associated circuit breakers in the cabinet and building provide sufficient power and overload protection. To prevent possible damage to the unit, isolate its power source from large switching loads (such as air conditioning motors, elevator motors, and factory loads).
- **Power interruptions** – The array modules will withstand the following applied voltage interruptions (with or without an integrated UPS):
 - **Input transient** – 50% of nominal voltage
 - **Duration** – one half cycle
 - **Frequency** – once every 10 seconds
- **Power failures** – After a total power failure, the unit will automatically perform a power-up recovery sequence without operator intervention once power is restored.

Interface Cables and Connections

This section provides information about array module interface cables and their appropriate connections.

The E2400 10x and E2400 14x array modules support Fibre Channel connections to drive modules. Each module has four GBIC connectors; two on each controller. The connectors may be fiber optic or copper (Figure 4-6). The connector type depends on what type of drive interface you order and what type of cable you will be using to attach the array module to the drive module.

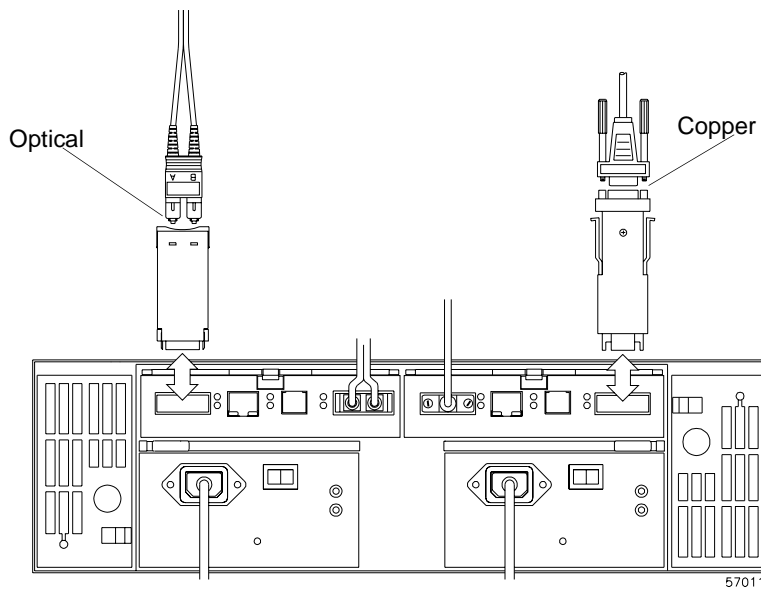

Figure 4-6 Optical and Copper GBICs

If you order optical GBIC connectors, you will need fiber optic cable. If you order copper GBIC minihubs, you will need copper fiber cable. Refer to [Table 4-8](#) for types and cable lengths available from your local dealer.

Table 4-8 E2400 10x and E2400 14x Array Module Fibre Channel Interface Cables

Descriptions				Order Information	
Cable	Data Rate	Transfer Speed	Maximum Range	Part Number	Length
Fiber optic Multi-mode, 50 micrometer, shortwave laser	100 MB/s	1062.5 Mb/s	0.5 kilometer	006-1086672	2 meter
				006-1086416	3 meter
				006-1086673	5 meter
				006-1086417	10 meter
Copper fiber Shielded, twisted pair, electrical signal	100 MB/s	1062.5 Mb/s	30 meters	006-1086682	2 meter
				006-1086672	3 meter
				006-1086483	5 meter
				006-1086473	10 meter

Array Module Site Preparation

Index

A

array module
 area requirements 4-2
 dimensions 4-4
 environmental requirements 4-7
 heat dissipation 4-7
 interface connections 4-12
 power cord routing 4-9
 power requirements 4-8
 site wiring requirements 4-11
 weight 4-2

C

cabinet
 area requirements 1-4
 dimensions 1-6
 environmental requirements 1-7
 features 1-2
 ladder cords 1-10
 power cords and receptacles 1-11
 power requirements 1-8
 site wiring requirements 1-12
 weight 1-5

cable
 copper fiber 2-13, 3-14, 4-13
 fiber optic 2-13, 2-14, 2-15, 3-14, 3-15, 4-13

command module
 area requirements 2-2
 dimensions 2-4
 environmental requirements 2-6
 interface connections 2-12
 power cord routing 2-8
 power requirements 2-8
 site wiring requirements 2-11
 weight 2-2

D

data transfer rates 2-13, 3-14, 4-13

dimensions
 array module 4-4
 cabinet 1-6
 command module 2-4
 drive module 3-4

drive module
 area requirements 3-2
 dimensions 3-4
 environmental requirements 3-7
 heat dissipation 3-7
 interface connections 3-13
 power cord routing 3-9
 power requirements 3-8
 site wiring requirements 3-12
 weight 3-2

E

environmental requirements
 array module 4-7
 cabinet 1-7
 command module 2-6
 drive module 3-7

E2400 10x
 dimensions 4-4
 environmental requirements 4-7
 heat dissipation 4-7
 interface connections 4-12
 weight 4-2

E2400 14x
 dimensions 4-5
 environmental requirements 4-7
 heat dissipation 4-7
 interface connections 4-12
 power requirements 4-8
 weight 4-3

E4400
 dimensions 2-4
 environmental requirements 2-6
 interface connections 2-12
 power requirements 2-8
 weight 2-2

E4600
dimensions 2-4
environmental requirements 2-6
interface connections 2-14
power requirements 2-8
weight 2-3

E5600
dimensions 2-4
environmental requirements 2-6
interface connections 2-14
power requirements 2-8
weight 2-3

F

FC-1 10x
dimensions 3-4
environmental requirements 3-7
heat dissipation 3-7
interface connections 3-13
power requirements 3-8
weight 3-2

FC-1 14x
dimensions 3-5
environmental requirements 3-7
heat dissipation 3-7
interface connections 3-13
power requirements 3-8
weight 3-3

FC-2 14x
dimensions 3-5
environmental requirements 3-7
heat dissipation 3-7
interface connections 3-15
power requirements 3-9
weight 3-3

I

interface connections
array module 4-12
command module 2-12
drive module 3-13

L

ladder cords, cabinet 1-10

M

multi-mode cable 2-13, 3-14, 4-13

O

optical, fiber interface 2-13, 2-14, 3-14, 3-15,
4-13

P

power cord routing
array module 4-9
command module 2-8
drive module 3-9
power requirements
array module 4-8
cabinet 1-8
command module 2-8
drive module 3-8

S

shortwave laser 2-13, 3-14, 4-13
site wiring requirements
array module 4-11
cabinet 1-12
command module 2-11
drive module 3-12

U

uninterruptible power supply (UPS) 2-8, 3-9,
4-9

W

weight
array module 4-2
cabinet 1-5
command module 2-2
drive module 3-2